

Reply should be addressed
to the Commanding Officer

REGISTERED

INS India
Dara Shukoh Road
New Delhi – 110 011

Quoting No: 427/Naval Uniform contract/TE

19 Sep 18

M/S _____

**REQUEST FOR PROPOSAL FOR CONCLUSION OF
CONTRACT FOR FABRICATION OF NAVAL UNIFORMS
NO. 1s, 2s, 8s, 10As, SHIRT WHITE F/S, COMBAT UNIFORM AND
TROUSER BLACK, FOR THE PERIOD OF ONE YEAR**

INSTRUCTIONS TO BIDDERS FOR FABRICATION OF NAVAL UNIFORMS

Sir,

We invite sealed tender for conclusion of contract for fabrication of various Naval Uniforms for a period of **ONE YEAR** w.e.f. date of signing of contract.

1. Bids in sealed cover are invited for fabrication of Naval Uniforms. Please super scribe the above-mentioned Title, RFP number and date of opening of the Bids on the sealed cover to avoid the Bid being declared invalid.

2. The address and contact numbers for sending Bids or seeking clarifications regarding this RFP are given below -

- (a) Bids/queries to be addressed to : **The Commanding Officer, INS India.**
- (b) Postal address for sending the Bids : **INS India, Dara Shukoh Road,
New Delhi-11**
- (c) Name/designation of the contact Officer : **LTR CDR MANISH KUNDU**
- (d) Telephone numbers of the contact Officer: **011-23010647**
- (e) E-mail ids of contact personnel/Mob No.: _____
- (f) Fax number: **011-23010647**

3. This RFP is divided into five Parts as follows:
 - a. **Part I** – Contains General Information and Instructions for the Bidders about the RFP such as the time, place of submission and opening of tenders, Validity period of tenders, etc.
 - b. **Part II** – Contains essential details of the items/services required, such as the Schedule of Requirements (SOR), Technical Specifications, Delivery Period, Mode of Delivery and Consignee details.
 - c. **Part III** – Contains Standard Conditions of RFP, which will form part of the Contract with the successful Bidder.
 - d. **Part IV** – Contains Special Conditions applicable to this RFP and which will also form part of the contract with the successful Bidder.
 - e. **Part V** – Contains Evaluation Criteria and Format for Price Bids.
4. **This RFP is being issued with no financial commitment and the Buyer reserves the right to change or vary any part thereof at any stage. Buyer also reserves the right to withdraw the RFP, should it become necessary at any stage.**

Part I – General Information to Bidders for Fabrication of Naval Uniforms

1. **Last date and time for depositing the Bids.** The sealed Bids should reach this office by **1000 hrs on 16 Oct 18**. The responsibility to ensure this lies with the Bidder.
2. **Manner of depositing the Bids.** The Technical and Commercial bids are to be submitted in two separate sealed envelopes, duly marked as “Technical Bid for Tender Enquiry No. Quoting No.: 427/Naval Uniform contract/TE and “Commercial Bid for Tender Quoting No.: 427/Naval Uniform contract/CE. The quotes are to be super scribed with your firm’s name, address, and official seal and ink-signed by an authorized representative of the Tenderer. Sealed Bids addressed to the, **The Commanding Officer, INS India, Dara Shukoh Road, New Delhi-11** should be either dropped in the Tender Box marked as **“TENDER FOR FABRICATION OF NAVAL UNIFORM”** or sent by registered post at the address given above so as to reach by the due date and time. Late tenders will not be considered. No responsibility will be taken for postal delays or non-delivery/ non-receipt of Bid documents. Bids sent by FAX or e-mail will not be considered (unless they have been specifically called for by these modes due to urgency).
3. **Time and Date for opening of Bids.** Technical Bids will be opened on **16 Oct 18 at 1500 hrs**. Commercial Bid opening will be intimated subsequently after approval of TEC.(If due to any exigency, the due date for opening of the Bids is declared a closed holiday, the Bids will be opened on the next working day at the same time or on any other day/time, as intimated by the Buyer)
4. **Location of the Tender Box.** Logistics Complex, INS India, Dara Shukoh Road, New Delhi – 110011. Only those Bids that are found in the tender box will be opened. Bids dropped in the wrong Tender Box will be rendered invalid.
5. **Place of opening of the Bids.** Logistics Complex, INS India, Dara Shukoh Road, New Delhi – 110011. The Bidders may depute their representatives, duly authorized in writing to attend the opening of Bids on the due date and time. Rates and important commercial/ technical clauses quoted by all Bidders will be read out in the presence of the representatives of all the Bidders. This event will not be postponed due to non-presence of your representative.
6. **Pre-Bid Meeting.** The representatives of the firms are requested to assemble at **in the office of Deputy Logistics officer (Clothing), INS India at 1500 hrs on 03 Oct 18** for pre-bid meeting prior submission of their bids. It is mandatory for all firms to attend Pre-bid meeting.
7. **Two-Bid System.** Only the Technical Bid would be opened on the time and date mentioned above. Date of opening of the Commercial Bid will be intimated after acceptance of the Technical Bids. Commercial Bids of only those firms will be opened whose technical Bids are found complete/ suitable after technical evaluation is done by the Buyer.
8. **Technical Bid.** The technical evaluation will be done by checking the requisite documents as per **Appendix ‘A’** followed by evaluation of stitched uniform samples as per Naval specifications. The specifications are placed at **‘Appendix B’**. Commercial Bid of firm technically qualifying will only be considered for commercial bid opening. The fabricated uniforms are to confirm to Naval Specifications. **The quality of material used**

for stitching i.e. zip, thread, buttons etc. will also be criteria for the inspection of uniform and the same will be required to be used during the operation of contract.

The decision of Technical Evaluation Committee regarding quality of stitching will be final and no correspondence regarding the same will be entertained thereof.

9. **Forwarding of Bids.** Bids should be forwarded by Bidders under their original memo / letter pad inter alia furnishing details like GSTN, Bank address with NEFT Account if applicable, etc. and complete postal & e-mail address of their office.

10. **Clarification regarding contents of the RFP.** A prospective bidder who requires clarification regarding the contents of the bidding documents shall notify to the Buyer in writing about the clarifications sought not later than 07 (seven) days prior to the date of opening of the Bids. Copies of the query and clarification by the purchaser will be sent to all prospective bidders who have received the bidding documents.

11. **Modification and Withdrawal of Bids.** A bidder may modify or withdraw his bid after submission provided that the written notice of modification or withdrawal is received by the Buyer prior to deadline prescribed for submission of bids. A withdrawal notice may be sent by fax but it should be followed by a signed confirmation copy to be sent by post and such signed confirmation should reach the purchaser not later than the deadline for submission of bids. No bid shall be modified after the deadline for submission of bids. No bid may be withdrawn in the interval between the deadline for submission of bids and expiration of the period of bid validity specified. Withdrawal of a bid during this period will result in Bidder's forfeiture of bid security.

12. **Clarification regarding contents of the Bids.** During evaluation and Comparison of bids, the Buyer may, at its discretion, ask the bidder for clarification of his bid. The request for clarification will be given in writing and no change in prices or substance of the bid will be sought, offered or permitted. No post-bid clarification on the initiative of the bidder will be entertained.

13. **Rejection of Bids.** Canvassing by the Bidder in any form, unsolicited letter and post-tender correction may invoke summary rejection with forfeiture of EMD. Conditional tenders will be rejected.

14. **Validity of Bids.** The Bids should remain valid till 180 days from the last date of submission of the Bids.

15. **Earnest Money Deposit.** Bidders are required to submit Earnest Money Deposit (EMD) for an amount of **Rs. 1,30,114.00 (Rupees One Lakh Thirty Thousand One Hundred and Fourteen only)** in favor of the **Commanding Officer, INS India**. The EMD may be submitted in the form of an Account Payee Demand Draft, Fixed Deposit Receipt, Banker's Cheque or Bank Guarantee from any of the public sector banks or a private sector bank authorized to conduct government business EMD is to remain valid for a period of forty-five days beyond the final bid validity period. EMD of the unsuccessful bidders will be returned to them at the earliest after expiry of the final bid validity and latest on or before the 30th day after the award of the contract. The Bid Security of the successful bidder would be returned, without any interest whatsoever, after the receipt of Performance Security from them as called for in the contract. EMD is not required to be submitted by those bidders who are registered with the Central Purchase Organization (e.g. DGS&D), National Small Industries Corporation (NSIC) or any Department of MoD or MoD itself. The EMD will be forfeited if the bidder withdraws or amends impairs or derogates from the tender in any respect within the validity period of their tender.

PART II – Essential Details to Bidders for Fabrication of Naval Uniform

1. **Schedule of Requirements.** The following uniforms are required to be stitched over a period of one year as per Naval Specifications (NU-2) Placed at **Appendix B'** in parts based on the number of the measurements undertaken as and when intimated by the contracting operating agency: -

<u>Sl. No.</u>	<u>Dress No.</u>	<u>Description</u>	<u>Annual Approx Quantity</u>
(a)	1s	Jacket D/B and Trouser Black Woolen	2100 Pairs
(b)	2s	Tunic White P/V GBD Trouser White P/V GBD	1800 Pairs
(c)	8s	Shirt White H/S P/V GBD Short White P/V GBD	1600 Pairs
(d)	10As	Shirt PV Light Blue H/S trouser Navy Blue GBD	3000 Pairs
(e)	Shirt White	Shirt White Full Sleeves P/C	2500 Pairs
(f)	Combat	Combat Dress Consisting of Shirt F/S and Trouser	300 Pairs
(g)	Trouser Black	Trouser Black of Woolen	1000 Pairs

Note: The cloth for fabrication of Naval Uniforms will be provided by Clothing store, INS India.

2. Notwithstanding the reference of specs in NU-2 for the following items, only the updated specs as indicated below are to be used in lieu as applicable to each uniform:-

- (a) **BUTTONS** - **IS 1461:2003.** Shape of Button has to be common across all garments and color of buttons is to be as specified in **NU-2** for respective garments.
- (b) **ZIPPERS** - Plastic Slide Fasteners (PSF) as per **IS : 14181-2002** (Part 1,2&3) White Amendment No.2 of March 2008 OR Equivalent.
- (c) **SEWING THREAD** - 100% Spun Polyester as per CQA (T&C), Kanpur Specs No. **IND/TC/0296(b)** OR Equivalent.
- (d) **FUSING/INTERLINING MATERIAL** - CQA(T&C), KANPUR Specs No. **IND/TC/2089(a)** for HDPE Dot printed fusible interlining.

3. **Technical Details.** As per Appendix 'A' attached with RFP. The technical bid should clearly indicate unconditional acceptance by the bidder of all clauses in the RFP. The technical bid would be evaluated based on the acceptance of RFP clauses and the compliance statement as per **Appendix 'A'**.

4. **Two-Bid System.** Bidders are required to furnish clause by clause compliance of specifications bringing out clearly the deviations from specification, if any. The bidders are advised to submit the compliance statement in the following format along with Technical Bid: -

Para No. of Appendix 'A'	Item Details	Compliance (Yes/No)	In case of noncompliance, deviation to be specified in unambiguous terms
--------------------------	--------------	---------------------	--

5. **Delivery Period** - The delivery of stitched uniforms is to be completed within 60 Days of placing the work order. **The supplier is required to collect the fabric from the Clothing Store, INS India, any delay in collection of fabric will be attributable to the supplier.** Please note that contract can be cancelled unilaterally by the Buyer in case items are not received within the stipulated delivery period. Extension of stipulated delivery period will be at the sole discretion of the Buyer, with applicability of LD clause.

6. **Delivery and Transportation:-** Delivery of stitched uniforms/ Local delivery at site of buyer will be provided by firm. The uniforms are to be neatly folded and packed in plastic covers and should be delivered in card board boxes with a content card placed on the box clearly bringing out the details of contents. Uniforms No. 1 and No. 2 are to be hanged on a plastic hanger and covered in a dress cover at the time of delivery.

7. **Consignee details:-** The Commanding Officer, INS India, Dara Shukoh Road, New Delhi-11.

8. **Delivery place:-** Clothing store, Logistics Complex, INS India, Dara Shukoh Road, New Delhi-11.

Part III - Standard Condition of FRP for Fabrication of Naval Uniform

The Bidder is required to give confirmation of their acceptance of the Standard Conditions of the Request for Proposal mentioned below which will automatically be considered as part of the Contract concluded with the successful Bidder (i.e. Seller in the Contract) as selected by the Buyer. Failure to do so may result in rejection of the Bid submitted by the Bidder.

1. **Law.** The Contract shall be considered and made in accordance with the laws of the Republic of India. The contract shall be governed by and interpreted in accordance with the laws of the Republic of India.

2. **Effective Date of the Contract.** The contract shall come into effect on the date of signatures of both the parties on the contract (Effective Date) and shall remain valid until the completion of the obligations of the parties under the contract. The deliveries and supplies and performance of the services shall commence from the effective date of the contract.

3. **Arbitration.** That in the event of any dispute or differences arising under the contract so executed and which could not be resolved through mutual discussions. In such circumstances, the customer and contractor may agree for arbitration. The Commanding Officer, INS India will appoint arbitrator or a cell of arbitration on his behalf to resolve the disputes. The decision of arbitrator taken after due consideration of factors brought out by both parties shall be final and binding in the jurisdiction of New Delhi. The venue of the arbitration shall be at the discretion of the arbitrator, Subject as aforesaid, the Arbitration Act and the rules there-under, the statutory modification thereof, for the time being in force, shall be deemed to apply to the arbitration proceedings under this condition.

4. **Penalty for use of Undue influence.** The Seller undertakes that he has not given, offered or promised to give, directly or indirectly, any gift, consideration, reward, commission, fees, brokerage or inducement to any person in service of the Buyer or

otherwise in procuring the Contracts or forbearing to do or for having done or forborne to do any act in relation to the obtaining or execution of the present Contract or any other Contract with the Government of India for showing or forbearing to show favour or disfavor to any person in relation to the present Contract or any other Contract with the Government of India. Any breach of the aforesaid undertaking by the Seller or any one employed by him or acting on his behalf (whether with or without the knowledge of the Seller) or the commission of any offence by the Seller or anyone employed by him or acting on his behalf, as defined in Chapter IX of the Indian Penal Code, 1860 or the Prevention of Corruption Act, 1986 or any other Act enacted for the prevention of corruption shall entitle the Buyer to cancel the contract and all or any other contracts with the Seller and recover from the Seller the amount of any loss arising from such cancellation. A decision of the Buyer or his nominee to the effect that a breach of the undertaking had been committed shall be final and binding on the Seller. Giving or offering of any gift, bribe or inducement or any attempt at any such act on behalf of the Seller towards any officer/employee of the Buyer or to any other person in a position to influence any officer/employee of the Buyer for showing any favour in relation to this or any other contract, shall render the Seller to such liability/ penalty as the Buyer may deem proper, including but not limited to termination of the contract, imposition of penal damages, forfeiture of the Bank Guarantee and refund of the amounts paid by the Buyer.

5. **Agents / Agency Commission.** The Seller confirms and declares to the Buyer that the Seller is the original manufacturer of the stores/provider of the services referred to in this Contract and has not engaged any individual or firm, whether Indian or foreign whatsoever, to intercede, facilitate or in any way to recommend to the Government of India or any of its functionaries, whether officially or unofficially, to the award of the contract to the Seller; nor has any amount been paid, promised or intended to be paid to any such individual or firm in respect of any such intercession, facilitation or recommendation. The Seller agrees that if it is established at any time to the satisfaction of the Buyer that the present declaration is in any way incorrect or if at a later stage it is discovered by the Buyer that the Seller has engaged any such individual/firm, and paid or intended to pay any amount, gift, reward, fees, commission or consideration to such person, party, firm or institution, whether before or after the signing of this contract, the Seller will be liable to refund that amount to the Buyer. The Seller will also be debarred from entering into any supply Contract with the Government of India for a minimum period of five years. The Buyer will also have a right to consider cancellation of the Contract either wholly or in part, without any entitlement or compensation to the Seller who shall in such an event be liable to refund all payments made by the Buyer in terms of the Contract along with interest at the rate of 2% per annum above LIBOR rate. The Buyer will also have the right to recover any such amount from any contracts concluded earlier with the Government of India.

6. **Access to Books of Accounts.** In case it is found to the satisfaction of the Buyer that the Seller has engaged an Agent or paid commission or influenced any person to obtain the contract as described in clauses relating to Agents/Agency Commission and penalty for use of undue influence, the Seller, on a specific request of the Buyer, shall provide necessary information/ inspection of the relevant financial documents/information.

7. **Non-disclosure of Contract documents.** Except with the written consent of the Buyer/ Seller, other party shall not disclose the contract or any provision, specification, plan, design, pattern, sample or information thereof to any third party.

8. **Liquidated Damages.** In the event of the Contractor's failure to submit the Bonds, Guarantees and Documents, supply the stores/goods and conduct trials, installation of equipment, training, etc as specified in this contract, the Buyer may, at his discretion, withhold any payment until the completion of the contract. The BUYER may also deduct from the CONTRACTOR as agreed, liquidated damages to the sum of 0.5% of the contract price of the delayed/undelivered stores/services mentioned above for every week of delay or part of a week, subject to the maximum value of the Liquidated Damages being not higher than 10% of the value of delayed stores.

9. **Termination of Contract.** The Buyer shall have the right to terminate this Contract in part or in full in any of the following cases:-

- (a) The delivery of the material is delayed for causes not attributable to Force Majeure for more than (02 months) after the scheduled date of delivery.
- (b) The Seller is declared bankrupt or becomes insolvent.
- (c) The delivery of material is delayed due to causes of Force Majeure by more than (04 months) provided Force Majeure clause is included in contract.
- (d) The Buyer has noticed that the Seller has utilized the services of any Indian/ Foreign agent in getting this contract and paid any commission to such individual/ company etc.
- (e) As per decision of the Arbitration Tribunal.

10. **Notices.** Any notice required or permitted by the contract shall be written in the English language and may be delivered personally or may be sent by FAX or registered pre-paid mail/ airmail, addressed to the last known address of the party to whom it is sent.

11. **Transfer and Sub-letting.** The Seller has no right to give, bargain, sell, assign or sublet or otherwise dispose of the Contract or any part thereof, as well as to give or to let a third party take benefit or advantage of the present Contract or any part thereof.

12. **Patents and other Industrial Property Rights.** The prices stated in the present Contract shall be deemed to include all amounts payable for the use of patents, copyrights, registered charges, trademarks and payments for any other industrial property rights. The Seller shall indemnify the Buyer against all claims from a third party at any time on account of the infringement of any or all the rights mentioned in the previous paragraphs, whether such claims arise in respect of manufacture or use. The Seller shall be responsible for the completion of the supplies including spares, tools, technical literature and training aggregates irrespective of the fact of infringement of the **supplies**, irrespective of the fact of infringement of any or all the rights mentioned above.

13. **Amendments.** No provision of present Contract shall be changed or Modified in any way (including this provision) either in whole or in part except Present Contract by an instrument in writing made after the date of this Contract and signed on behalf of both the parties and which expressly states to amend the present contract

14. **Taxes and Duties:-**

- (i). If Bidder desires to ask for service tax the same must be specifically stated. In the absence of any such stipulation, it will be presumed that the prices include all such charges and no claim for the same will be entertained.
- (ii). If reimbursement of any Duty/Tax is intended as extra over the quoted prices, the Bidder must specifically say so. In the absence of any such stipulation it

will be presumed that the prices quoted are firm and final and no claim on account of such duty/tax will be entertained after the opening of tenders.

(iii). If a Bidder chooses to quote a price inclusive of any duty/tax and does not confirm inclusive of such duty/tax so included is firm and final, he should clearly indicate the rate of such duty/tax and quantum of such duty/tax included in the price. Failure to do so may result in ignoring of such offers summarily.

(iv). If a Bidder is exempted from payment of any duty/tax up to any value of supplies from them, he should clearly state that no such duty/tax will be charged by him up to the limit of exemption which he may have. If any concession is available in regard to rate/quantum of any Duty/tax, it should be brought out clearly. Stipulations like, the said duty/tax was presently not applicable but the same will be charged if it becomes leviable

later on, will not be accepted unless in such cases it is clearly stated by a Bidder that such duty/tax will not be charged by him even if the same becomes applicable later on.

In respect of the Bidders, who fail to comply with this requirement, their quoted prices shall be loaded with the quantum of such duty/tax which is normally applicable on the item in question for the purpose of comparing their prices with other Bidders.

(v). Any change in any duty/tax upward/downward as a result of any statutory variation in excise taking place within contract terms shall be allowed to the extent of actual quantum of such duty/tax paid by the supplier. Similarly, in case of downward revision in any duty/tax, the actual quantum of reduction of such duty/tax shall be reimbursed to the Customer by the Contractor. All such adjustments shall include all reliefs, exemptions, rebates, concession etc. if any obtained by the Seller.

Part IV – Special Conditions of RFP for Fabrication of Naval Uniform

The Bidder is required to give confirmation of their acceptance of Special Conditions of the RFP mentioned below which will automatically be considered as part of the Contract concluded with the successful Bidder (i.e. Seller in the Contract) as selected by the Buyer. Failure to do so may result in rejection of Bid submitted by the Bidder.

1. **Performance Guarantee.** The Bidder will be required to furnish a Performance Guarantee by way of Bank Guarantee through a public sector bank or a private sector bank authorized to conduct government business (ICICI Bank Ltd., Axis Bank Ltd or HDFC Bank Ltd.) for a sum equal to 10% of the contract value within 30 days of signing of contract. Performance Bank Guarantee should be valid up to 60 days beyond the date of expiry of the contract.
2. **Option Clause.** The contract will have an Option Clause, wherein, the Buyer can exercise an option to procure an additional 50% of the original contracted quantity in accordance with the same Terms & Conditions of the present contract. This will be applicable within the Currency of the contract. The bidder is to confirm the acceptance of the same for inclusion in the contract. It will be entirely the discretion of the buyer to place the Repeat order or not.
3. **Repeat Order Clause.** The contract will have a Repeat Order Clause, wherein, the Buyer can order upto 50% quantity of the item under the present contract within six months from the date of supply/ successful completion of this contract, the cost, terms & conditions remaining the same. The bidder is to confirm acceptance of this clause. It will be entirely the discretion of the Buyer to place the Repeat order or not.
4. **Tolerance Clause.** To take care of any change in the requirement during the period starting from issue of RFP till placement of the contract, Buyer reserves the right to 25% plus/minus increase or decrease the quantity of the required goods upto that limit without any change in the terms & conditions and prices quoted by the Seller. While awarding the contract, the quantity ordered can be increased or decreased by the Buyer within this tolerance limit.
5. **Payment terms.** The payment terms are as follows:-
 - (a) 100% Payment will made through PCDA (N) after delivery of items and producing of documents and after obtaining satisfactory report from Commanding Officer, INS India.
 - (b) No advance payment will be made.
 - (c) It is mandatory to the supplier/vendor to indicate their bank account number and other relevant e-payment details so that payments can be made through ECS/NEFT mechanism instead of payment through cheques.
 - (d) **Financial Capabilities of the firm:-** The firm should have financial capability for fabrication of the uniforms. This payment will not be linked to clearance bills by INS India/ DCDA (N).
6. **Advance Payments.** No advance payment(s) will be made.

7. **Fall clause.** The following fall clause will form part of the contract placed on successful Bidder –

(a). The price charged for services under the contract by the Seller shall in no event exceed the lowest prices at which the Seller sells the services or offer to sell stores of identical description to any persons/organisation including the purchaser or any department of Central government or any Department of state government or any statutory undertaking the central or state government as the case may be during the period till performance of all supply Orders placed during the currency of the rate contract is completed.

(b). If at any time, during the said period the Seller reduces the price, sells or offer to sell such services to any person/organisation including the Buyer or any Dept, of central Govt. or any Department of the State Government or any Statutory undertaking of the Central or state Government as the case may be at a price lower than the price chargeable under the contract, the shall forthwith notify such reduction or sale or offer of sale to the Director general of Supplies & Disposals and the price payable under the contract for the stores of such reduction of sale or offer of the sale shall stand correspondingly reduced.

8. **Risk & Expense clause.** In the event of the contractor to comply with the contractual obligations, the Commanding Officer, INS India, at his discretion, will be free to make alternative arrangement at the risk and expenses of the contractor on the prevailing market rates. Expenses incurred on such risk and expense shall be debited from the payment accruing to the contractor in future.

9. **Force Majeure.** Should any Force Majeure circumstances arise, each of the contracting party shall be excused for the non-fulfillment or for the delayed fulfillment of any of its contractual obligations, if the affected party within (07 days) of its occurrence informs the other party in writing. Force Majeure shall mean fires, floods, natural disasters or other acts, that are unanticipated or unforeseeable, and not brought about at the instance of the party claiming to be affected by such event, or which, if anticipated or foreseeable, could not be avoided or provided for, and which has caused the non-performance or delay in performance, such as war, turmoil, strikes, sabotage, explosions, quarantine restriction beyond the control of either party. A party claiming Force Majeure shall exercise reasonable diligence to seek to overcome the Force Majeure event and to mitigate the effects thereof on the performance of its obligations under this contract.

10. **Police Verification.** Not Applicable

11. **Earliest Acceptance Year of Manufacturer.** Not Applicable

12. **Buyer Furnished Equipment.** The fabrics will be provided by clothing store, INS India to the contractor for fabrication of uniforms as per the stipulated quantities prescribed for each uniform by the AHSP from time to time. The frequency of issue would be at the discretion of the Commanding Officer, INS India. **The contractor is required to collect the fabric from the Logistics complex, Ins India any delay in supply of stitched uniforms due to late collection of fabric by the contractor would be attributable to the firm for calculation of LD, and if delay in issue of fabric is occurred from Clothing Store, INS India than delay would not be attributable to the firm for calculation of LD. At the time of collection of fabric the authorized representative of**

the firm is required to check quantity, quality and colour shade of the fabric. Any further complaint in this regard will not be accepted. The list of fabrics is as follows:-

- (a) Cloth White P/V Gab.
- (b) Cloth Black Baratheia
- (c) Cloth White
- (d) Cloth Navy Blue CC P/V Gab.
- (e) Cloth Light Blue CC P/V Gab.
- (f) Shirt F/S cloth
- (j) Combat uniform cloth.

13. **Transportation Clause.** Delivery of Stitched uniforms/ local delivery at site of Clothing Store, INS India will be undertaken by the firm.

14 **Inspection Authority.** The inspection of stitched uniforms will be carried out by DLOGO (Clothing), INS India on receipt of stitched uniforms at consignee's premises. In case of any ill fitment, variation of shade etc, the stitched uniform is to be replaced by the supplier at its own cost.

15. **Joint Receipt Inspection.** NA

16. **Franking Clause.** NA

17. **Claims.** The following claims clause will form part of the contract placed on successful Bidder:-

- (a) The claims may be presented either:
 - (i) On quantity of the stores, where the quantity does not correspond to the quantity shown in the Packing List/ Insufficiency in packing, or
 - (ii) On quality of the stores, where the quality does not correspond to the quality mentioned in the contract.

(b) The quantity claims for deficiency of quantity shall be presented within 45 days of completion of acceptance of goods. The quantity claims shall be submitted to the Seller as per DPM-22 (Available in MoD website and can be given on request).

(c) The Seller shall collect the defective or rejected goods from the location nominated by the Buyer and deliver the repaired or replaced goods at the same location under Seller's arrangement.

(d) Claims may also be settled by reduction of cost of goods under claim from bonds submitted by the Seller or payment of claim amount by Seller through demand draft drawn on an Indian Bank in favour of Principal Controller/ Controller of Defence Accounts concerned.

(e) The quality claims will be raised solely by the Buyer and without any certification/ countersignature by the Seller's representative stationed in India.

18. **Warranty.** The store supply against the order shall be deemed to bear a warranty of the supplier against defective material, workmanship and performance for a period of 12 months from the date of receipt at the consignee depot. If during this period the fabrication is defective, the same shall be replaced immediately with free of any charge or cost, after due inspection and acceptance by the Inspecting Officer. In case of a

uniform being rejected, the supplier will have to procure the cloth from the customer on payment and fabricate it free of cost. The rejected uniform will be returned to the supplier.

19. **Product Support.** NA

20. **Annual Maintenance Contract (AMC) Clause.** NA

21. **Price Variation (PV) Clause.** NA

22. **Measurement of Sizes.** The firm would have to take measurements of individuals at place intimated by contract Concluding or Operating Agency. The measurements will be undertaken at the premises of Logistics Complex, INS India, however Contractor would have to take the measurement at other places also if deemed necessary by the Contract Operating Agency.

Part V – Evaluation Criteria & Price Bid issues of RFP for Fabrication of Naval Uniform

1. **Evaluation Criteria.** The broad guidelines for evaluation of Bids will be as follows:

(a). Only those Bids will be evaluated which are found to be fulfilling all the eligibility and qualifying requirements of the RFP, both technically and commercially.

(b) In respect of Two-Bid system, the Technical Bids forwarded by the Bidders will be evaluated by the Buyer with reference to the technical characteristics of the equipment as mentioned in the RFP. The compliance of Technical Bids would be determined on the basis of the parameters specified in the RFP. The Price Bids of only those Bidders will be opened whose Technical Bids would clear the technical evaluation.

(c) The Lowest Bid will be decided upon the lowest price quoted by the Particular Bidder as per the Price Format given at Para 2 below. The consideration of taxes and duties in evaluation process will be as follows:

(i) In cases where only indigenous Bidders are competing, all taxes and duties (including those for which exemption certificates are issued) quoted by the Bidders will be considered. The ultimate cost to the Buyer would be the deciding factor for ranking of Bids.

(ii) In cases where both foreign and indigenous Bidders are competing, following criteria would be followed:-

(aa) In case of foreign Bidders, the basic cost (CIF) quoted by them would be the basis for the purpose of comparison of various tenders.

(ab) In case of the indigenous Bidders, Service Tax on fully formed equipment would be offloaded.

(ac) Sales tax and other local levies, i.e. octroi, entry tax would be ignored in case of indigenous Bidders.

(d) The Bidders are required to spell out the rates of VAT/Service Tax, etc in unambiguous terms; otherwise their offers will be loaded with the maximum rates of duties and taxes for the purpose of comparison of prices. If Service Tax is intended as extra, over the quoted prices, the Bidder must specifically say so. In the absence of any

such stipulation it will be presumed that the prices quoted are firm and final and no claim on account of such duties will be entrained after the opening of tenders. If a Bidder chooses to quote a price inclusive of any duty and does not confirm inclusive of such duty so included is firm and final, he should clearly indicate the rate of such duty and quantum of Service Tax included in the price. Failure to do so may result in ignoring of such offers summarily. If a Bidder is exempted from payment of Service duty upto any value of supplies from them, they should clearly state that no Service Tax will be charged by them up to the limit of exemption which they may have. Applicable later on, in respect of the Bidders who fail to comply with this Requirement, their quoted prices shall be loaded with the quantum of Service Tax which is normally applicable on the item in question for the purpose of comparing their prices with other Bidders.

(e) If there is a discrepancy between the unit price and the total price that is obtained by multiplying the unit price and quantity, the unit price will prevail and the total price will be corrected. If there is a discrepancy between words and figures, the amount in words will prevail for calculation of price.

(f) The Lowest Acceptable Bid will be considered further for a Supply Order after complete clarification and price negotiations as decided by the Buyer. The Buyer will have the right to award contract to L1 firm as a whole.

(g) Any other criteria as applicable to suit a particular case.

2. **Price Bid Format:** The Price Bid Format is given below and Bidders are required to fill this up correctly with full details:

(a).

<u>Sl. No.</u>	<u>Dress No.</u>	<u>Description</u>	<u>(Annual Quantity in Pairs</u>	<u>Basic Rate tendered for stitching and delivery at Depots</u>	<u>Taxes, if any(inciate amount and rate of tax)</u>	<u>Total rate inclusive of all taxes</u> <u>In figure</u> <u>in words</u>
(a)	No 1	Jacket Black DB Woolen	2100 Pairs.			
		Trouser black DB Woolen				
(b)	No 2	Tunic White P/V GBD	1800 Pairs.			
		Trouser White P/V GBD				
(c)	8s	Shirt White PVGBD H/S	1600 Pairs.			
		Short White P/V GBD				
(d)	10A	Shirt CC P/V Light Blue	3000 Pairs.			

		H/S				
		Trouser Blue GBD				
(e)	Shirt	Shirt white F/S	2500 Nos.			
(f)	Combat Dress	Combat Uniform	300 Nos.			
(g)	Trouser Black	Trouser Black Woolen	1000 Nos.			

(b) Is Service Tax extra?

If yes, mention the following:-

- (i) Total value of services on which Service Tax is leviable.
- (ii) Rate of Service Tax leviable;
- (iii) Total value of Service Tax leviable.

Whether exempt for paying service tax (indicate yes/no)

(c) Any other taxes/ duties/ overheads/ other costs.

- (i) Total value on which Tax is leviable.
- (ii) Rate of Tax leviable.
- (iii) Total value of Tax leviable.

Whether exempt for paying tax (indicate yes/no)

(d) Grand Total.

(e) This RFP is being issued with no financial commitment and Commanding officer, reserves the right to withdraw the RFP and changed or vary any part thereof at any stage. The Commanding Officer, INS India also reserves the right to disqualify any vender, should it be so necessary at any stage on ground of National Security.

(f) Please acknowledge receipt.

Yours faithfully,

X-----X-----X

(Manish Kundu)
Lieutenant Commander
Dy. Logistics Officer (Clo)
for Commanding Officer

Schedule of Requirement of Technical Bid

Guidelines for Preparation of Technical Bid: The Technical Bid should contain following information and details so as to enable the board of officers assess the firms financially, technically and infrastructure/ resources wise to undertake the said job:-

- (a) Indicate whether Earnest Money Deposit (EMD) as per Para 15 of Part I of the Tender Enquiry has been attached.
- (b) Indicate acceptance of Payments Terms as indicated in Para 5 of Part IV of the Tender Enquiry.
- (c) Indicate acceptance of Standard Conditions of Contract (SCOC) and other terms and conditions given in the Tender Enquiry:-
 - (i) Registration details form.
 - (ii) Registered Office Address, Telephone No.
 - (iii) Registering Agency.
 - (iv) IT Certificate, GSTN, PAN No./ REGD. No.
 - (v) EMD of **Rs. _____**/- (Rupees _____)
 - (vi) Past experience two years in execution of Govt. Contract (with Central & State) preferably Defence; Copy of the order to be enclosed.
 - (vii) Past Performance report from the last contract concluding/ operating authorities.
 - (viii) Is firm in a banned/ barred list?
 - (ix) Capacity verification will be carried out before Commercial Bid opening.
 - (x) Certified document indicating minimum annual turnover of Rs.15,00,000.00 (Rupees Fifteen Lakhs only).
 - (xi) Submission of samples of No. 1s, 2s, 8A, 8s, Combat and 10A uniforms (the cloth for the fabrication can be obtained from clothing store, INS India on payment basis.
 - (xii) No. of machine held (Minimum 10 industrial sewing machines)
 - (xiii) No. of workers employed (Minimum 15 workers)

(xiv) The firm's would be required to set up facility/workshop for measurement taking & modification/ alteration within 10-15 Km radius of INS India premises.

(d) Machinery compulsorily to be available:-

- (i) Single needle sewing machine suitable to undertake expertise jobs such as the front and seem attachment, cuff making, sleeve placket making, collar attaching, cuff attaching etc.
- (ii) Edge cutting Machine suitable for making collar.
- (iii) Five stitching inter locking Machine for making side over lock cum stitch.
- (iv) Button hole machine for high speed lock stitch straight button holing.
- (v) Button stitch machine for optimized service friendly, perfect positioning of cuffs and collar point, front placket by means of special guides.
- (vi) Cutting machine of at least 8 inches in length capable of cutting cloth in a layer.
- (vii) Blind stitching machine.
- (viii) Bar tracking machine for loop and pocket ends.

(e) Machinery desired to be available: -

- (i) Automatic fabric spreading machine
- (ii) Computer aided designer for marking and grading
- (iii) Automatic pocket welting machine

(f) Additional Information:-

- (i) Location of firms, workspace and environment.
- (ii) No of employees engaged in apparel manufacturing.
- (iii) Achievements including high orders (Enclose copies of supporting documents).

Note : The premises of the firm, may get inspected, in order to ascertain the availability of above mentioned machines.

NAVAL UNIFORM SPECIFICATIONS

CHAPTER - 17

SAILOR'S WINTER JACKET
(NHQ/DCV/9511/W/02)

Applicability ▼

1. These specifications outline the manufacturing details of the sailor's winter jacket worn with the winter black trousers (No 1 & 3 dresses).

Materials ▼

2. The materials required for fabrication of the sailor's jacket are identical to the officer's winter jacket (Chapter 16).

Manufacture ▼

3. **General.** The jacket shall be made from black polyester wool (Barathea), designed on a double-breasted coat style front with padded stand and fall collar.

4. **Design.** The garniture, design, fabrication parameters and salient features will be same as for winter jacket of officers, except the following:-

- (a) There will be no vents at the back side.
- (b) There will be only 3 gilt buttons size 1 (2.4 cm) of sailor's design on each side in front
- (c) The cut pockets at forepart will have 6 cm deep flaps.
- (d) The jacket's length shall reach up to the bottom point of the fly.
- (e) The horizontal distance between the two rows of buttons shall be 11 cm. The vertical distance between two buttons shall vary between 9 to 11 cm depending upon height of the individual.

5. **Other Clauses.** All other clauses shall conform in all respects to the officer's winter jacket (Chapter 16).

Sketches ▼

6. Sketches showing various details/dimensions of the sailor's winter jacket are placed at Appendix PR to this Chapter.

SAILOR'S WINTER JACKET

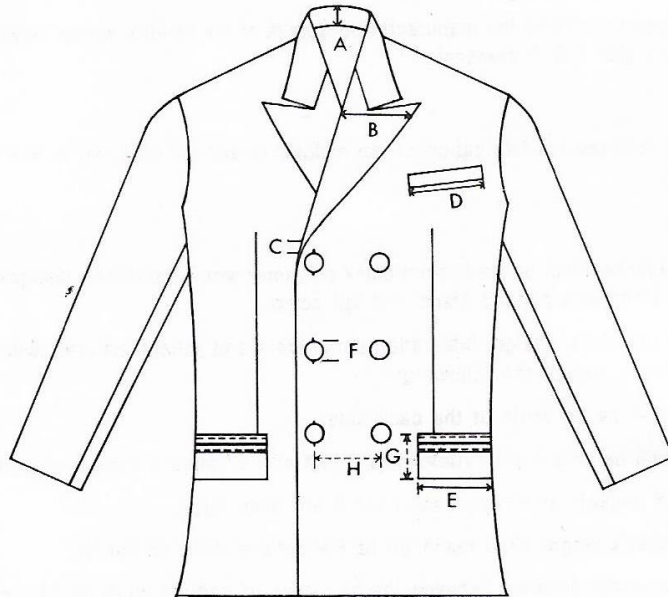

FRONT

Legend:

A - Inside of collar folded	- 3.5 cm
B - Width of lapel	- 9.0 cm
C - Distance of top button from lapel fold	- 2.0 cm
D - Left chest pocket	- 10.0 cm
E - Lower pocket opening	- 15.0 cm
F - Girth buttons	- 2.4 cm
G - Pocket flap depth	- 6.0 cm
H - Distance between buttons	11.0 cm



BACK

CHAPTER - 20

WINTER BLACK TROUSERS (NHQ/DCV/9511/W/05)

Applicability ▼

1. These specifications relate to winter black trousers worn with winter black jacket (No 1 & 3 dresses) and winter mess jacket (No 5 dress).

Salient Features ▼

2. The salient features of the garment are:-

- | | | |
|----------------------|---|---|
| (a) Waistband | - | 4 cm wide. |
| (b) Belt loops | - | 8 nos, 1.2 cm wide. |
| (c) Pleats | - | One 1.5 cm deep in front on each side. |
| (d) Dart | - | One on each side at the back. For women officers, two darts on each side at the back. |
| (e) Fly | - | Top 3 cm tapering to 1.5 cm. |
| (f) Side Pockets | - | 16 cm opening starting 4 cm below waistband lower edge. |
| (g) Length of Pocket | - | 33 to 36 cm. |
| (h) Hip Pocket | - | 12 cm wide. |
| (i) Bottom of Leg | - | 45 to 48 cm. |
| (k) Fly zip | - | 22 to 28 cm. |

Materials ▼

3. The trousers shall be manufactured from the materials as per details below :-

Item		Material
(a) Body	-	Polyester wool barathe black (60% wool 40% polyester).
(b) Lining for body, pockets, stay piece and crotch piece	-	Black polyester cloth (100% polyester)
(c) Sewings (for all sewings)	-	Black spun polyester sewing thread.
(d) Plastic zip	-	Plastic slide fastener in black tape.
(e) Hooks and eyes	-	Stainless steel hooks and eyes.
(f) Overlocking	-	Black spun polyester sewing thread.
(g) Buttons	-	Black plastic buttons 1.6 cm dia.

Manufacture ▼

4. **General.** The trousers shall be tailored from polyester wool barathe black cloth. These are to be conventional fly-fronted style with plain bottom, shaped from instep to front. Each front shall have one pleat (1.5 cm) wide outward facing, centre of the pleat shall fall at the centre of the front.

Each back shall have one dart (1.5 cm approx) facing back seam. In case of women officers, there shall be two darts on each side at the back. The side, leg and back seams shall be plain. The raw edges of side and leg seams shall be overlocked. The back seam shall have two rows of hand stitching and the inlay shall be 4 cm with the raw edges stitched just after single turn.

5. Fly. The trousers shall have a fly having width at the top 3 cm tapering from the turning point to 1.5 cm at the tacking point and shall be lined with black polyester cloth. The fly shall be provided with a plastic slide fastener (zip).

6. Pockets. The trousers shall be provided with two side pockets. The pockets are to be made from black polyester cloth. The opening of the side pockets shall be 16 cm and tacked at both ends. The upper tack shall be located at 4 cm below the waist-band seam. The length of the pockets shall be between 33 cm and 36 cm. The width at the top shall be from 13.5 to 15.5 cm and at the tack it shall be from 17 cm to 19 cm. A cut pocket 12 cm wide is to be provided on the right hip. It should be placed 6 cm below the waistband. A loop and button arrangement is to be provided for securing the pocket. In addition, an inside thief pocket 12 cm deep and 10 cm wide is to be provided in front on the right side.

7. Waistband. There shall be a waistband 4 cm wide. It shall have a front extension piece 8 cm long. It is to be lined with good quality black polyester lining cloth and interlined with buckram canvas. It shall also be provided with stainless steel hooks and eyes for securing purposes. It is to be provided with 1.2 cm wide equally spaced 8 belt loops - 4 on each side commencing 2.5 cm distance from the back seam.

8. Bottom Size. The trousers are to be uniformly tapered. No tapering at the knee or flaring at the ankle is permissible. The circumference at the bottom of the leg is to be between 45 cm and 48 cm depending upon size. The bottom fold shall be 6 cm. The leg length shall be 1.5 cm longer than that needed to touch the instep.

9. Size Scale. The trousers shall conform to the dimensions specified in the size scale given in Appendix G, Chapter 7.

10. Sealed Sample. As given in Para 2 of Appendix B, Chapter 1.

11. Marking of Stores. Each pair of trousers shall be provided with a woven size label showing nomenclature, size and cat. no. of the store, the manufacturer's name or his recognised trade-mark and the month and year of manufacture. The label shall be of white art silk and threads of contrast colour will be used. It shall be attached to the waist band lining on the right hand side at the centre.

Inspection ▼

12. Acceptance Mark. It shall be affixed on the inside of the waistband at the back within 10 cm of the marking label.

13. Pre-inspection Declaration. As given in Para 3 of Appendix B, Chapter 1.

Warranty ▼

14. As given in Para 4 of Appendix B, Chapter 1.

Packing and Marking ▼

15. As given in Appendix C, Chapter 1.

Sketches ▼

16. Sketches showing details are given at Appendix V to Chapter 7.



WHITE TROUSERS

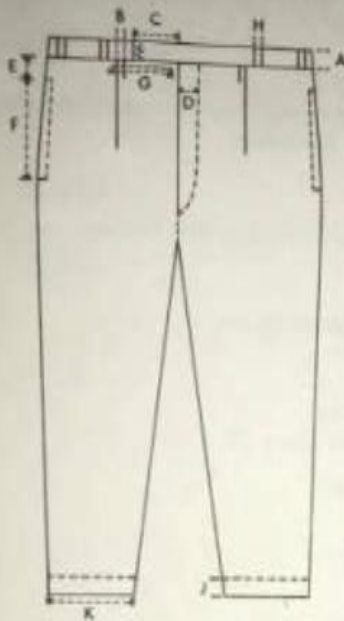

FRONT

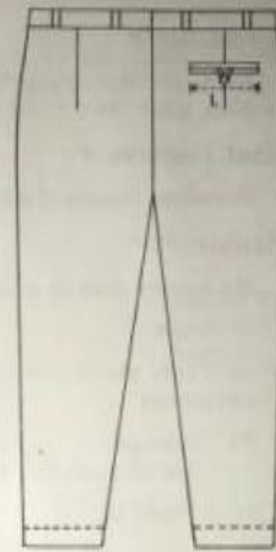

BACK

Legend

A - Waist band	- 4.0 cm
B - Pleats in front	- 1.5 cm
C - Extension piece	- 8.0 cm
D - Fly front	- 3.0 cm
(Tapering to 1.5 cm at bottom)	
E - Distance between pocket opening & waist band	- 4.0 cm
F - Pocket opening	- 16.0 cm
G - Inside thigh pocket	- 12.0 cm
H - Belt loops width	- 1.2 cm
J - Bottom fold (hemmed)	- 6.0 cm
K - Bottom opening	- 22.5 to 24 cm
L - Hip pocket width	- 12.0 cm wide

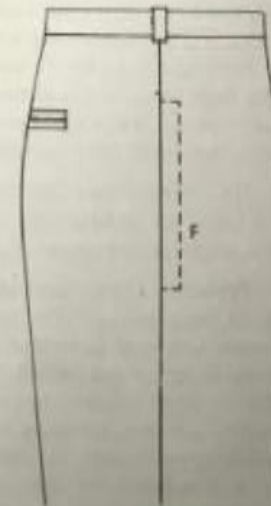

PROFILE

CHAPTER - 4

TUNIC (NHQ/DCV/9511/S/04)

Applicability ▼

1. These specifications cover the details of the tunic worn with the white trousers (No 2 & 4 dresses).

Salient Features ▼

2. The salient features of the garment are as under :-

- | | | |
|--------------------------|---|---|
| (a) Stand-up collar | - | 3.5 cm at back, 3 cm in front. |
| (b) Front overlap | - | Left over right, 4 cm. |
| (c) Patch pockets | - | 13.5 cm x 12.5 cm. |
| (d) Fold hemming | - | Bottom of tunic 3.5 cm.
Bottom of sleeves 7.5 cm.
Pocket fold width 2.5 cm. |
| (e) Side opening at back | - | 13 cm. |
| (f) Brass hooks and eyes | - | Quality items. |

Materials ▼

3. The under mentioned materials are required for fabrication of the tunic :-

Item	Material
(a) Body, collar, tab and hook facing	- Cloth polyester cotton gaberdine weave 138 cm wide (70 : 30).
(b) Sewings	- Sewing thread spun polyester white.
(c) Hooks & eyes for collar	- Hooks & eyes of brass universal or any other equally strong non-rusting material.

Manufacture ▼

4. **General.** The tunic shall be fabricated from bright white gaberdine weave cloth. The front portion of the tunic shall be in two pieces i.e. open front and single-breasted closing left over right with a 4 cm overlap. It shall have five No 1 size (2.4 cm dia) crested gilt buttons. The top of the top button shall be 1 cm below the seam of the collar and the bottom button 20 cm to 24 cm from the bottom depending upon the height. The remaining buttons are to be spaced at equal intervals. The corners of the front and back pieces are to be finished in square shape.

5. **Collar.** The tunic shall have a stand-up collar with a width of 3 cm in front and 3.5 cm at the back. Two hooks and two matching eyes of non-rusting material and a throat tab are to be fitted in the front portion of the collar. The throat tab made from the basic material will act as a backing to the hooks and eyes and protect the throat from any irritation due to rubbing. The hooks and eyes when secured shall neither leave gap nor create an overlap. The collar shall be made from two layers of the basic material and each layer shall be in a single piece.

6. **Back.** The back portion of the tunic shall also be in two pieces, joined by a centre seam. There shall be two side openings, each 13 cm long at the bottom of each seam and with a 4 cm inner to outer overlap where the back joins the front. The bottom of the tunic all around should have a fold hemmed with 3.5 cm width.

7. Front. There shall be two vertical shaping darts on the front pieces, one on each side. These darts shall begin from the bottom of the chest pockets, one third the distance from the outer edge of the pocket and run vertically down two fifth the distance between the bottom edge of the pocket and the bottom of the tunic and equal in length to the darts under the sleeves. The darts on the back pieces, one on each piece, shall originate from the sleeve joint and run vertically down.

8. Pockets. Each front piece shall have a patch pocket without flap. The size of the pocket shall be 13.5 cm deep and 12.5 cm wide. The top part of the pocket shall be made by stitching the raw edges with a turn in of 1 cm and then turning the seam inside by 2.5 cm so that no seam is visible at the upper part of the pocket. The pocket width fold of 2.5 cm is to be hemmed. The bottom corners of the pocket shall be finished with rounded corners. The pocket opening shall be secured by a triangular tack by machine stitching at both ends.

9. Buttons. The gilt buttons when secured shall be adequately tight so that their faces remain parallel to the fabric. The button anchors shall point straight down. The button-hole stitching shall not show more than 2 mm outside the button.

10. Length. The tunic length shall be 8 cm below the bottom point of the fly. The sleeve length shall be such as to cover the wrist joint. The turn up of the sleeve shall be hemmed at a height of 7.5 cm. The sleeves shall show no wrinkles at the shoulder joint nor shall they project above the shoulder seam. The curve of the sleeve shall be such that when the hand is dropped to its natural position, no wrinkle shall be visible on the sleeve. The fitting of the tunic shall be such that when the arms are swung to the horizontal, the tunic shall not be pulled out of position.

11. Stitches. The tunic shall be assembled with lock stitches, regulated at 40 to 45 stitches per dm (10 cm). All ends shall be securely fastened off.

12. Size Scale. The tunics shall conform to the dimensions specified in Appendix F to these specifications.

13. Sealed Sample. As given in Para 2 of Appendix B, Chapter 1.

14. Marking. Each tunic shall be stitched with a white cloth label 14 cm x 2.5 cm on the inside of the neck. The label shall be printed with the manufacturer's name, recognised trade-mark, month and year of manufacture, brief nomenclature, cat no and size of the garment.

Inspection ▼

15. Acceptance Mark. Textile marking stamp of 1.3 cm size shall be used to stamp the body of the tunic on bottom inside border using indelible ink in token of having accepted the store after due inspection.

16. Pre-inspection Declaration. As given in Para 3 of Appendix B, Chapter 1.

Warranty ▼

17. As given in Para 4 of Appendix B, Chapter 1.

Packing and Marking ▼

18. As given in Appendix C, Chapter 1.

Sketches ▼

19. Sketches showing various details/dimensions of the tunic are placed at Appendix S to this Chapter.



SIZE SCALE - TUNIC

Size	Size Round		Length from collar seam at		Half width of back
	Chest when buttoned	Waist when buttoned	Front	Back	
			cm	cm	
cm	cm	cm	cm	cm	cm
94	94	81	61	66	17.5
97	97	84	63	68	18.5
101	101	88	63	68	18.5
104	104	91	65	70	19.5
108	108	95	65	70	19.5
111	111	98	67	72	20.5
115	115	102	67	72	20.5
119	119	106	69	74	21.5
Tolerance	±1.5	±1.5	±1.5	±1.5	

TUNIC

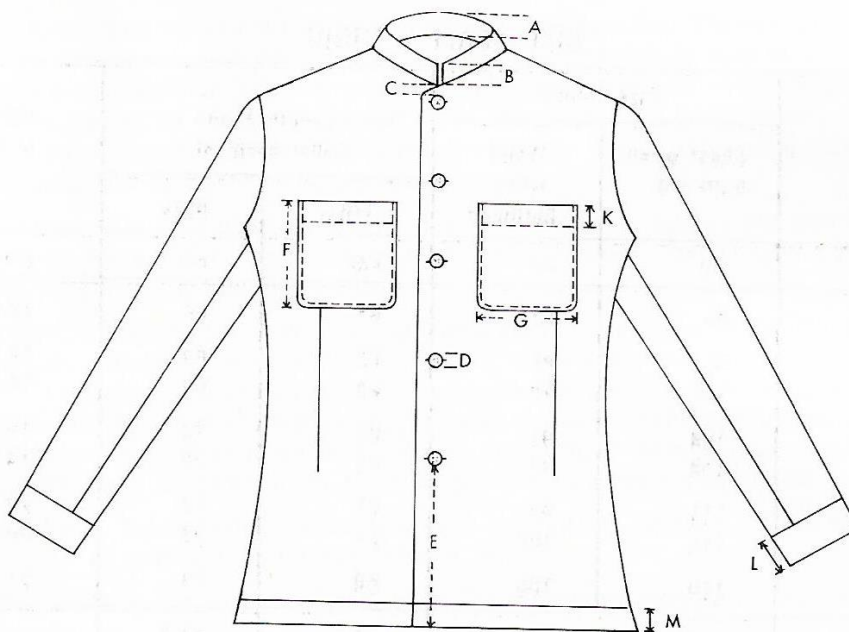

FRONT

Legend

A - Collar width back	- 3.5 cm
B - Collar width front	- 3.0 cm
C - Distance of top button from collar	- 1.0 cm
D - Gilt button size 1	- 2.4 cm dia
E - Distance of last button from bottom	- 20 to 24.0 cm
F - Pocket length	- 13.5 cm
G - Pocket width	- 12.5 cm
H - Vent opening	- 13.0 cm
J - Vent overlap	- 4.0 cm
K - Pocket fold	- 2.5 cm
L - Sleeve bottom	- 7.5 cm
M - Bottom fold	- 3.5 cm

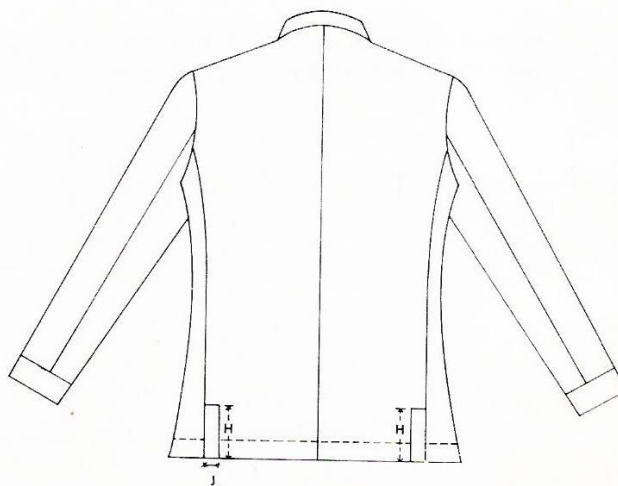

BACK

BLUE HALF SLEEVED SHIRT
(DCV/CG/NAVY/7/2013)

Applicability

1. These specification relate to the manufacturing details of the Blue half sleeved shirt for Dress No.10A.

Description

2. The Blue half sleeved shirt has a seven button front closure, a two piece collar medium spread with stays, two patch pockets with flap and button closure, shoulder epaulets, with curved bottom hem.

3. **Raw Material Specifications**

<u>Items</u>	<u>Material</u>	<u>Size / Count</u>	<u>Color</u>	<u>Description</u>
Fabric	Cloth, Gaberdine, Polyester Viscose, Light Blue as per IHQ(N) of MoD specs DCV/CG/NAVY/07/2013			
Sewing Thread	Spun Polyester	Count : 20 Tex X 3	Matching	3 ply
Collar stay	Nylon/plastic	Medium	Transparent	Non removable
Fusing	Woven	GSM: Light Wt. -150 Medium Wt.- 210	White	(a) Light weight (placket & pocket flap) (b) Medium Weight (collar & epaulet)
Button	Polyester/Nylon	1.1cms	White translucent (Suggested)	Flat sew through four hole button
Label	Polyester	(a) Size Label (b) Care Label	Black on white	Printed/woven

Manufacturing details.

4. **Predicted Measurements.** A chart showing predicted measurements for Men as well as Women is shown at Appendix 1 and 2.

5. **Pictorial Presentation.** The pictorial presentation of the shirt is placed at Appendix 3.

6. **Seam.**

- (a) SPI – 11 stitches per inch
- (b) Lock stitch is to be used for joining the shirt components.

- (c) 4-thread over lock stitch is used to finished raw edges of sleeve and side seam.
- (d) Back yoke should be finished with top stitch.

7. **Assembling**

- (a) **Front and Back.** Front and back panels must be stitched together at the sides. They are joined at the seam lined to form a simple, narrow, superimposed seam and stitched together using a 4-thread over lock stitch.
- (b) **Women.** The back of shirt is in one piece, having two double ended darts at waist. These darts will give better fitting and shape to the shirt.
- (c) **Shoulder seams.** Seams at the shoulder may be completed before or after the collar is attached.
- (d) **Collar.** A collar is made up of two pieces i.e collar and collar stand. Both are reinforced with fusible interlining, which gives the collar stiffness and strength. A fused interlined collar means the interlining is heated and glued together through a fusing machine. The laminated surface of the interlining material is kept facing the outer layer of the collar. The upper stitching of the collar shall be finished with a inform distance of 5 mm from the edge. The finished collar shall be attached to the collar stand.
- (e) **Label.** Labels stitched on the sample shirt are the dummy labels. (Should be referred only for the placement). Label will provide information about the size and washing instructions.
- (f) **Size label.** Stitch centre horizontally at centre back inside collar stand.
- (g) **Wash care label.** Should be stitched 3 inch above hem, inside the wearer's left side seam.

8. **Quality checks**

- (a) **Seams**
 - (i) Stitching is secure and even
 - (ii) Balanced tension
 - (iii) Free from puckering, and skipped or broken stitches
 - (iv) Free from tangles or knots
 - (v) Reinforced at ends with backstitching or knotting
 - (vi) Loose threads have been clipped
 - (vii) Seam allowances are flat and smooth
 - (viii) Even in width
- (b) **Collar**
 - (i) Free from bulkiness

- (ii) Collar points sharp and flat
- (iii) Shape symmetrical on right and left
- (iv) Seamline in just under the edge of the collar
- (v) Understitching should hold under-collar in place
- (v) Collar stays are inconspicuous

(c) **Sleeve Joint** A properly executed sleeve joint provide a seamless look with continuity of design pattern from the shoulder to the sleeve.

(d) **Pocket**

- (i) Flat and smooth
- (ii) Positioned correctly
- (iii) Even topstitching
- (iv) Upper corners are reinforced
- (v) Seam allowances on square corners are flat and inconspicuous

(e) **Button stitching** Thread is passed through the holes and the material, to bind the button in place, either using a button sewing machine or by hand with cross-stitch, number of stitches per cycle should be minimum 16 of single thread. If hand sewn the thread shall be wound round the button six times to secure it properly.

(f) **Button-holes** The button-holes shall be made with not less than 8 stitches per cm when made by hand or 9 stitches per cm when made by machine. The button-holes may be eyelet end type or bar end type and be either bar tacked or taper finished.

(g) **Bottom hem** The garment hem should be sewn with an overedge stitch, resulting in a flexible hem. The tension of the stitch should be loose enough to allow stretching the garment without tearing the fabric. Alternative hem styles include a combination of edge finishing stitches.

(h) **Finishing operations** Shirts should be inspected for flaws in the fabric, stitching, and thread. Shirts are to be pressed through steam before they are packaged.

(i) **Sleeves.** The shirt should have half sleeves in one piece and finished under arm seam with lock stitch and then 4 thread overlocked. The hems of sleeves are first finished before they are fitted into the garment, since it is easier to hem the fabric. The sleeves shall be attached to the arm hole. Shirt sleeves can be finished with Russian turning.

(k) **Pockets.** Two patch pocket with flap on the chest without lining is sewn onto shirt. The bottom corners to the pockets shall be finished diagonal cut of a square. The pocket mouth fold should be 1 inch, and pocket opening shall be secured by a triangular tack by machine stitching at both the ends. The flap is lined with light weight fusing. Stitch the flap sections together with right sides together. So that the flap will later conceal the raw edges, stitch inwards on the slant from the attachment line. Secure seam ends. Trim back the seam

allowances, cut across the corners and snip into the curves. Turn the flaps, press and topstitch. With the right side underneath, stitch flap over the pocket, Press flap downwards and sew a buttonhole. Pockets may be attached to the garment with automated setters, so the operator only has to arrange the fabric pieces, and the mechanical setter positions the pocket and stitches the seam.

(l) **Front placket.** Front opening is folded to create placket. Apply interlining to reinforce the button hole placket area. Then placket is top stitched 1/4th inch from the edge on both the sides. Button hole placket is fold back from the front edge with lock stitch.

(m) **Pocket Flap**

- (i) Flap covering the buttons.
- (ii) Flat, smooth, and even in width
- (iii) Free from bulkiness
- (iv) Corners are secure and symmetrical

(n) **Buttons**

- (i) Placed in the direction of strain from the button (eliminates gapping)
- (ii) The shirt for women has to be provide for push buttons between two button holes for additional fixing to avoid any gapping, especially in areas prone to straining.

(o) **Placement of buttons**

- (i) On right front
- (ii) Overlap wide enough to cover button without gapping

(p) **Buttonholes**

- (i) Reinforced with interfacing
- (ii) Even in length, width, and equally spaced
- (iii) Appropriate length (large enough to allow button to pass through easily, yet small enough to hold garment closed)
- (iv) Placed with the grain or yarn direction of the fabric

(q) **Fitting**

- (i) There must be ample room around the chest and shoulders to permit free use of the arms, without binding.
- (ii) The collar of the shirt will fit smoothly around the neck with sufficient room
- (iii) The shoulder/arm seam will reach a point to the outer edge of the shoulder joint.

(r) **Plackets**

- (i) Flat, smooth, and neat
- (ii) Free from bulkiness
- (iii) Secure and durable;
- (iv) Free from raw or raveling edges

(s) Sleeves

- (i) Sleeve should be balanced on the arm
- (ii) Hangs neither forward nor backward on the arm
- (iii) Doesn't hug the arm
- (iv) Ease at the cap
- (v) Seamline is smooth and even

Annexure -1

Predicted Measurements for Men's Blue Half Sleeve Shirt

<u>S. NO</u>	<u>Description of Measurements (Inches)</u>	<u>Code</u>	<u>Tol +/-</u>	<u>36</u>	<u>38</u>	<u>40</u>	<u>42</u>	<u>44</u>	<u>46</u>
1	Front Length From HPS	A	½	28	29	30	31	32	33
2	Centre Back	B	½	30.5	31.5	32.5	33.5	34.5	35.5
3	Chest When Buttoned (1"Below Armhole)	C	½	42	44	46	48	50	52
4	Waist When Buttoned (19"Below)	D	½	41	43	45	47	49	51
5	Hem	E	½	44	46	48	50	52	54
6	Shirt Bottom Hem Fold	F	0	.25	.25	.25	.25	.25	.25
7	Sleeve Length	G	¼	10	10	10.25	10.25	10.5	10.5
8	Sleeve Hem	H	¼	14	14	15	15	16	16
9	Sleeve Hem Fold	I	0	1.5	1.5	1.5	1.5	1.5	1.5
10	Back Yoke Length	J	¼	17.75	18.25	18.75	19.75	20.0	20.25
11	Back Yoke Width	K	1/8	4.5	4.5	5	5	5	5
12	Collar Length (Button Hole To Button)	L	¼	15.5	16.5	16.5	17	17.5	17.5
13	Collar Width,(At Centre Back)	M	1/8	1.75	1.75	1.75	1.75	1.75	1.75
14	Collar Point	N	1/8	3	3	3	3	3.25	3.25
15	Collar Stand Width At Center Front	O	1/8	1	1	1	1	1	1
16	Center Back	o	1/8	1.25	1.25	1.25	1.25	1.25	1.25
17	Shoulder Epaulets Width At Seam	P	1/8	2	2	2	2	2	2
18	Width At Edge	p	1/8	13/8	13/8	13/8	13/8	13/8	13/8
19	Shoulder Button From Neck Point	Q	0	1.5	1.5	1.5	1.5	1.5	1.5
20	Pocket Width	R	1/8	5	5	5	5	5	5
21	Length	r	1/8	5.5	5.5	5.5	5.5	6	6

Pictorial presentation of Uniform

FRONT VIEW AND BACK VIEW

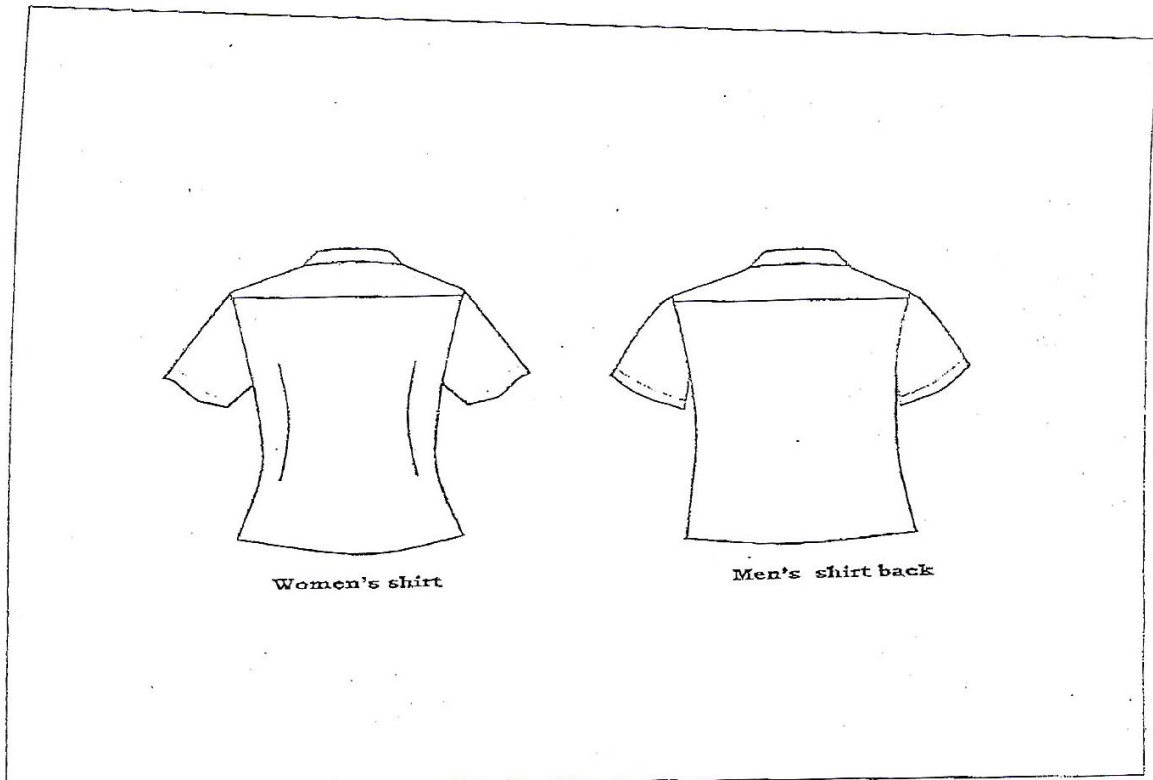
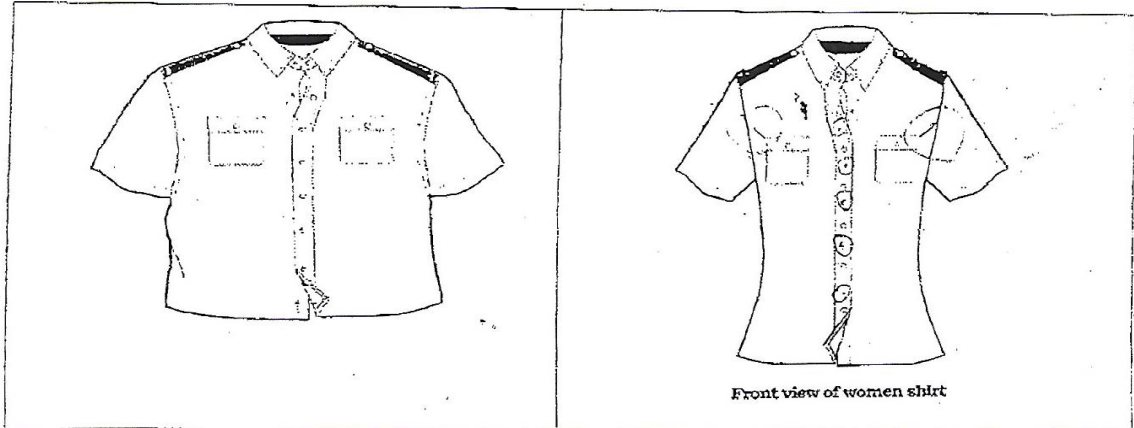

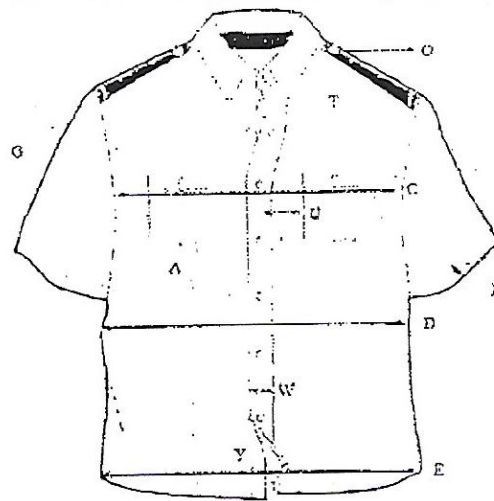

Front View (men)

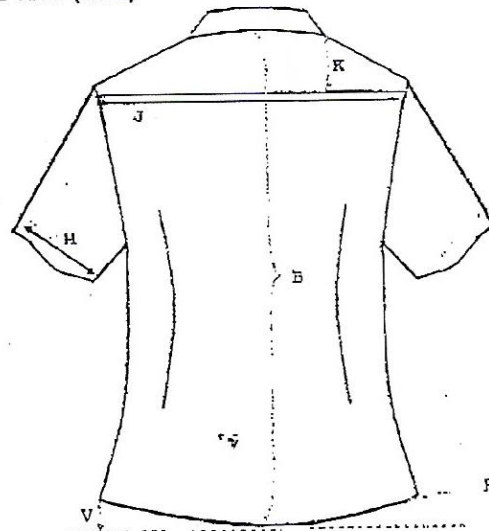

Back View (women)

OTHER COMPONENTS

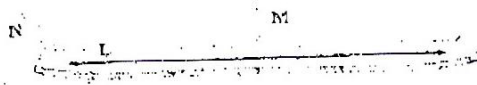

Collar



Collar stand



Epaulet



Patch Pocket with Flap

OTHER COMPONENTS

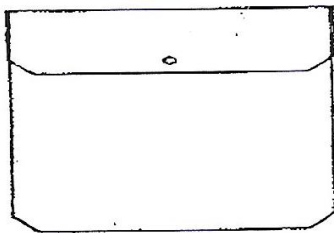

Flap pocket

OTHER COMPONENTS

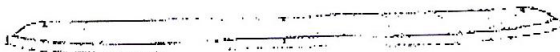

Stand

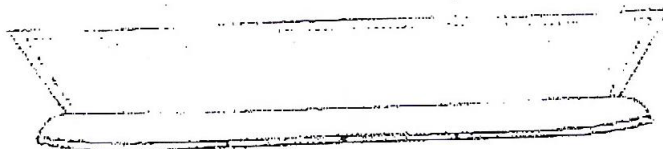

Collar

TROUSER NO. 2S AND 10A

CHAPTER - 7

WHITE TROUSERS (NHQ/DCV/9511/S/07)

Applicability ▼

1. These specifications cover the manufacturing details of white trousers worn with tunic (No 2 & 4 dresses), white bush jacket (No 4A dress) and white half sleeved shirt (No 8A dress).

Salient Features ▼

2. The salient features of the garment are outlined below :-

- | | | |
|------------------------|---|--|
| (a) Waist band | - | 4 cm wide. |
| (b) Belt loops | - | 8 nos, 1.2 cm wide. |
| (c) Pleats | - | 1.5 cm deep in front, one on each side and turned outward. |
| (d) Fly | - | Top 3 cm tapering to 1.5 cm. |
| (e) Darts | - | One on each side at the back.
(For women officers, two darts on each side at the back). |
| (f) Side Pockets | - | 16 cm opening. |
| (g) Length of Pockets | - | 33 to 36 cm. |
| (h) Hip Pocket | - | 12 cm wide. |
| (j) Bottom of Leg | - | 45 to 48 cm. |
| (k) Fly zip | - | 22 to 28 cm. |
| (l) Lining/pocket | - | Basic material. |
| (m) Zip, hook, buttons | - | Quality items. |

Materials ▼

3. The trousers shall be manufactured from the materials as per details below :-

Item	Material
(a) Body and all other components	- White polyester cotton cloth gaberdine weave 138 cm wide (70 : 30) and white polyester cotton plain weave for 8A dress.
(b) Sewings (for all sewings)	- Spun polyester white sewing thread.
(c) Plastic zip	- Plastic slide fastener in white tape.
(d) Hooks and eyes	- Brass or stainless steel hooks and eyes.
(e) Overlocking	- Spun polyester white sewing thread.

Manufacture ▼

4. **General.** The trousers shall be tailored from bright white gaberdine/plain weave cloth conventionally fly-fronted style with plain bottom, shaped from instep to front. Each front shall have one pleat, 1.5 cm wide, outward facing. Centre of the pleat shall fall at the centre of the front. Each back shall have one dart (1.5 cm approx) facing back seam. In case of women officers, there shall be two darts on each side at the back. The side, leg and back seams shall be plain. The raw edges of side and leg seams shall be overlocked. The back seam shall have two rows of machine stitching and the inlay shall be 1 cm and the raw edges stitched just after single turn.

5. Fly. The trousers shall have a fly having width at the top, 3 cm tapering from the turning point to 1.5 cm at the tacking point and shall be lined with body material. The fly shall be provided with a white plastic slide fastener (zip).

6. Pockets. The trousers will be provided with two side pockets and one inside front thief pocket made from the body material. The opening of the side pockets shall be 16 cm and tacked at both ends. The upper tack shall be located at 4 cm below the waist band seam. The length of the pocket shall be between 33 cm and 36 cm. The width at the top shall be from 13.5 cm to 15.5 cm and at the tack it shall be from 17 cm to 19 cm. The inside thief pocket shall be 12 cm in length (deep) and 9 cm in width. A cut pocket 12 cm wide is to be provided on the right hip with a loop and a button for securing.

7. Waistband. The trousers shall have a waistband 4 cm wide. It shall have a front overlapping extension piece 8 cm long. The waistband is to be lined and interlined with the basic material. It shall also be provided with stainless steel or brass eyes and hooks for securing purposes. The waistband is to be provided with 8 cm wide equally spaced 8 belt loops - 4 on each side commencing 2.5 cm from the back seam.

8. Bottom Size. The trousers' legs are to be uniformly tapered. No tapering at the knee or flaring at the ankle is permissible. The circumference at the bottom of the leg is to be between 45 cm and 48 cm depending on the size. The bottom fold is to be hemmed with hand stitching and the width of the fold shall be 6 cm. The leg length shall be 1.5 cm longer than that needed to touch the instep.

9. Stitches. The trousers shall be assembled with lock stitches regulated at 35 to 40 stitches per decimetre (10 cm). All ends shall be securely fastened off and loose threads trimmed off.

10. Size Scale. The trousers shall conform to the dimensions specified in the size scale given in Appendix G to these specifications.

11. Sealed Sample. As per Para 2 of Appendix B, Chapter 1.

12. Marking of Stores. Each pair of trousers shall be provided with a woven cloth label 14 cm x 2.5 cm showing nomenclature, size and cat. no. of the store, the manufacturer's name or his recognised trade-mark and the month and year of manufacture. The label shall be of white art silk and threads of contrast colour will be used. It shall be attached to the waist band lining on the right hand side at the centre.

Inspection ▼

13. Acceptance Mark. It shall be affixed on the inside of the waist band at the back within 10 cm of the marking label. Only brass acceptance mark of 1.3 cm size shall be used.

14. Pre-inspection Declaration. As given in Para 3 of Appendix B, Chapter 1.

Warranty ▼

15. As given in Para 4 of Appendix B, Chapter 1.

Packing and Marking ▼

16. As give in Appendix C, Chapter 1.

Sketches ▼

17. Sketches showing various details/dimensions of the trousers are placed at Appendix V to this Chapter.



SIZE SCALE - WHITE TROUSERS

Size	Side Length	Leg Length	Size Round				Length of Zip
			Seat	Waist	Knee	Bottom	
cm	cm	cm	cm	cm	cm	cm	cm
72	103	75	100	72	50	45	22
74	107	78	102	74	50	45	24
78	107	78	106	78	52	46	24
79	111	81	107	79	52	46	25
83	111	81	111	83	54	47	25
87	111	81	115	87	54	47	25
87	115	84	115	87	54	47	26
92	119	84	119	92	56	48	26
92	119	87	119	92	56	48	28
94	119	87	122	94	56	48	28
Tolerance	±1.5	±0.5	±1.5	±1.5	±0.5	±0.5	±0.5

Notes: (For all sizes)

- | | | |
|--|---|---------|
| 1. Opening of side pockets between tacks | - | 16 cm |
| 2. Distance of waist band from side pocket top opening | - | 04 cm |
| 3. Inside pocket length | - | 12 cm |
| 4. Inside pocket width | - | 09 cm |
| 5. Width of waist band front & back | - | 04 cm |
| 6. No. of belt loops | - | 08 Nos. |
| 7. Width of belt loops | - | 1.2 cm |
| 8. Width of bottom fold | - | 06 cm |
| 9. Width of hip pocket | - | 12 cm |
| 10. Length of front extension band on waist | - | 08 cm |

Dimensions of the pockets:-

Size of Trousers (cm)	72,74,78	79,83,87	92&94
1. Length (cm)	33	35	36
2. Width (cm) At top	13.5	14.5	15.5
3. Width (cm) At tack	17.0	18.0	19.0

WHITE TROUSERS

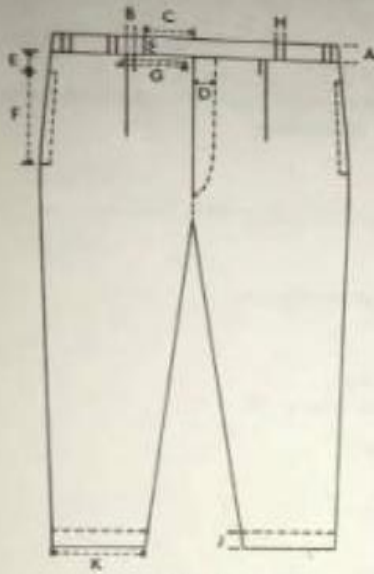

FRONT

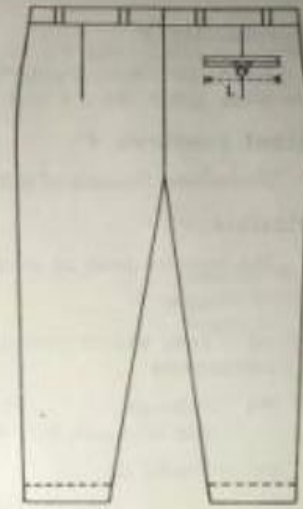

BACK

Legend

A - Waist band	- 4.0 cm
B - Pleats in front	- 1.5 cm
C - Extension piece	- 8.0 cm
D - Fly front	- 3.0 cm
(Tapering to 1.5 cm at bottom)	
E - Distance between pocket opening & waist band	- 4.0 cm
F - Pocket opening	- 16.0 cm
G - Inside thigh pocket	- 12.0 cm
H - Belt loops width	- 1.2 cm
J - Bottom fold (hemmed)	- 6.0 cm
K - Bottom opening	- 22.5 to 24 cm
L - Hip pocket width	- 12.0 cm wide

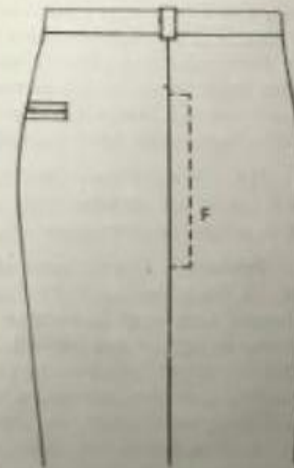

PROFILE

CHAPTER - 1

WHITE HALF SLEEVED SHIRT (NHQ/DCV/9511/S/01)

Applicability ▼

1. These specifications relate to the manufacturing details of the white half sleeved shirt worn with white shorts/skirts (No 8 dress), white trousers (No 8A dress) and black summer trousers (No 6A dress).

Salient Features ▼

2. The salient features of the garment are:-

- | | | |
|--------------------|---|-------------------------------|
| (a) Collar | - | 3.5 cm wide and 7 cm fall. |
| (b) Pockets | - | 13 cm X 12.5 cm. |
| (c) Yoke | - | 5.5 cm at centre and at ends. |
| (d) Sleeve Hemming | - | 2.5 cm. |
| (e) Buttons | - | Translucent white buttons. |

Materials ▼

3. The shirt shall be manufactured from the following materials:-

Item		Material
(a) Body and all other components	-	Plain weave white polyester cotton cloth (70 : 30).
(b) Lining for collar	-	HDPE coated fusible inter-lining fabric.
(c) Sewing of shirt including overlocking, buttons and button holes	-	White spun polyester sewing thread.
(d) Buttons	-	White translucent buttons 1.1 cm dia.

Manufacture ▼

4. **General.** The shirt shall be tailored from bright white polyester cotton plain weave cloth. The cloth shall conform to the specifications prescribed for fabrication of white shorts/skirt and white trousers. The front portion of the shirt shall be in two pieces i.e. full open front. The foreparts shall be cut wide enough to obtain 4.5 cm wide turn in on the left side and 4.5 cm wide button stand (both including selvages) on the right side up to the bottom.

5. **Pockets.** There shall be two plain patch pockets on the chest, one on either side. Top of the pockets shall be made by stitching the raw edges with a turn in of 1 cm and then turning the seam inside by 2 cm so that no seam is visible at the upper part of the pocket. The bottom corners of the pockets shall be finished diagonal cut of a square. The pocket opening shall be secured by a triangular tack by machine stitching at both the ends. The length of the pockets shall be 13 cm and width 12.5 cm.

6. **Buttons.** The shirt shall be provided with six white translucent buttons 1.1 cm diameter on the right hand side of front opening including one on the collar stand. The button-holes shall be made at corresponding positions on the left hand side.

7. **Back.** The back shall be in one piece having two darts at waist and shall be stitched between two layers of yoke at shoulder. The front and back pieces shall be joined together at the sides by plain stitching and then overlocked with white polyester sewing thread. The front pieces shall be joined at the shoulder by first stitching with the under piece of the yoke and then with the outer piece. The bottom edges of the front and back portions shall be hemmed 6 mm with raw edges turned in. There shall be a rounded vent on each side at the bottom of the

shirt. The two darts to be provided at the back are for better fitting and also to give a shape to the shirt. The width of the yoke at the centre and at ends shall be 5.5 cm.

8. Collar. The collar shall be made from two layers of the basic material and each layer will be in a single piece. The interlining material is to be placed in between the two layers of the basic fabric. It is to be ensured that the laminated surface of the interlining material is kept facing the outer layer of the collar. The collar is then to be fused by heat process. The upper stitching of the collar shall be finished with a uniform distance of 5 mm from the border. The finished collar shall be attached to the gorge with two rows of machine stitching i.e. one row from inside and another row from outside. The width of the collar folded at centre of back shall be 3.5 cm and fall at front 7 cm.

9. Sleeves. The shirt shall have half sleeves in one piece and finished with under arm plain stitching and then overlocked with white polyester sewing thread. The sleeves shall be attached to the arm hole by plain seam. The bottom of the sleeves shall be hemmed 2.5 cm with raw edges turned in. The sleeve length shall be restricted so that the edge of the sleeve is 1.5 cm above the inside elbow crease.

10. Stitching of Buttons. The buttons shall be stitched with not less than 16 stitches of single thread or 8 stitches of double thread through the buttons. When the buttons are stitched by hand, the thread shall be wound round the stitches three times when double or six times when single thread is used to form a shank.

11. Button-holes. The button-holes shall be made with not less than 8 stitches per cm when made by hand or 9 stitches per cm when made by machine. The button-holes may be eyelet end type or bar end type and be either bar tacked or taper finished.

12. Stitching. The shirt shall be assembled throughout with lock stitches regulated at 40 to 45 stitches per dm (10 cm). All ends shall be securely fastened off.

13. Size Scale. The shirt shall conform to the dimensions specified in Appendix A to this Chapter.

14. Sealed Sample. As given in Para 2 of Appendix B to this Chapter.

15. Marking. Each shirt shall have a white cloth label 14 cm x 2.5 cm stitched on the yoke lining inside below the collar seam. It shall have the following details woven with contrast colour threads.

- (a) Brief nomenclature.
- (b) Cat no. and size.
- (c) Manufacturer's name and/or his recognised trade-mark.
- (d) Month and year of manufacture.

Inspection ▼

16. Acceptance Mark. Textile marking stamp of 1.3 cm size shall be used to stamp on the reverse of the cloth label using indelible ink in token of having accepted the stores after due inspection.

17. Pre-inspection Declaration. As given in Para 3 of Appendix B to this Chapter.

Warranty ▼

18. As given in Para 4 of Appendix B to this Chapter.

Packing and Marking ▼

19. Packing and Marking. As given in Appendix C to this Chapter.

Sketches ▼

20. Sketches showing various details/dimensions of the shirt are placed at Appendix P to this Chapter.

WHITE HALF SLEEVED SHIRT



Legend

- | | |
|--|-----------------------------|
| A - Collar | - 7.0 cm |
| B - Pocket length | - 13.0 cm |
| C - Pocket width | - 12.5 cm |
| D - Pocket fold | - 2.0 cm |
| E - Sleeve hemming | - 2.5 cm |
| F - Distance of sleeve to elbow folded | - 1.5 cm |
| G - Buttons | - 1.1 cm |
| H - Collar width folded at back | - 3.5 cm |
| J - Yoke | - 5.5 cm at centre & at end |

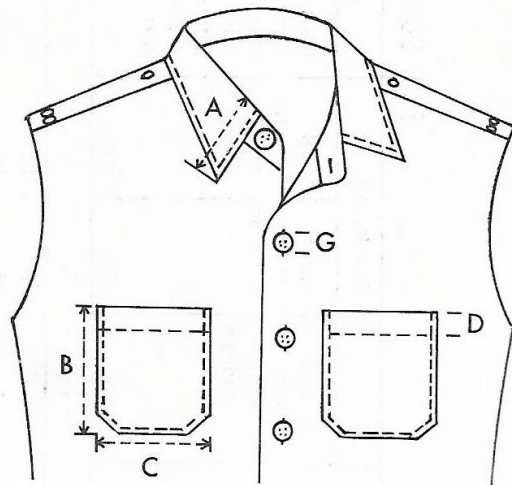

CHAPTER - 10

WHITE SHORTS (NHQ/DCV/9511/S/10)

Applicability ▼

1. These specifications relate to the white shorts worn with white half sleeved shirt (No 8 dress).

Salient Features ▼

2. The salient features of the garment are specified below :-
- | | | |
|--------------------------------------|---|--|
| (a) Waist band | - | 5 cm wide. |
| (b) Pleats | - | 1.5 cm deep outward facing. |
| (c) Fly | - | Top 3 cm tapering to 1.5 cm. |
| (d) Side pockets | - | 16 cm opening. |
| (e) Length of pocket | - | 33 to 36 cm. |
| (f) Fly zip | - | 22 to 28 cm. |
| (g) Waist adjustment strap | - | 8 cm x 3 to 2 cm tapered. |
| (h) Bottom hem fold | - | 6 cm. |
| (i) Circumference of shorts at thigh | - | 15 cm more than the thigh of the individual. |
| (k) Pockets lining | - | Basic material. |
| (l) Zip, hooks, buttons | - | Quality items. |

Materials ▼

3. The shorts shall be manufactured from the following materials :-

Item		Material
(a) Body and all other components	-	White polyester cotton cloth plain weave 138 cm (70 : 30).
(b) Sewings (for all sewings)	-	Spun polyester white sewing thread.
(c) Plastic zip	-	Plastic slide fastener in white tape.
(d) Hooks and eyes	-	Brass or stainless steel hooks and eyes.
(e) Overlocking	-	Spun polyester white sewing thread.

Manufacture ▼

4. **General.** The shorts shall be tailored from bright white polyester cotton plain weave cloth. The cloth shall conform to the specification prescribed for fabrication of white half sleeved shirts to ensure matching shade of No 8 dress.

5. **Front.** Each front shall have one 1.5 cm deep pleat outward facing and one dart on each side at the back. The shorts shall have a fly having width at the top 3 cm tapering from the turning point to 1.5 cm at the tacking point and shall be lined with basic material. The fly shall be securely bar tacked at the bottom. It shall be provided with a plastic slide fastener (zip).

6. **Pockets.** The shorts shall have two side pockets and one inside thief pocket in front made from the same basic material. The opening of the side pockets shall be 16 cm and tacked at both

ends. The upper tack shall be located at 4 cm below the waist band seam. The length of the side pocket shall be between 33 cm and 36 cm. The width at the top shall be from 13.5 cm to 15.5 cm and at the tack it shall be 17 cm to 19 cm. The inside thief pocket shall be 12 cm in length (deep) and 9 cm in width.

7. Waistband. The shorts shall have an extended waistband with straight end. The extension of the belt beyond the edge of the left forepart shall be 8 cm. The waistband shall be 5 cm wide. It shall be lined and interlined with the basic material. The waist band shall also be provided with two sets of concealed hooks and eyes. The stitch at the joint of the shorts and the waistband should be concealed. A stay piece measuring 5 cm x 5 cm shall also be provided at the end of the extended waistband in between lining and interlining for reinforcement.

8. Strap. The shorts shall be provided with a tapered strap one on each side, made from double layer of the basic material, with two buttons, the first button to be in line with the side seam and the second button 2.5 cm away (button ends) from it towards front. When finished the length of the strap shall be 8 cm, the broader end 3 cm wide and the narrower end 2 cm. A button hole 1 cm away from the narrow end shall be centrally made. The broader end shall be stitched within the waist band.

9. Buttons. The buttons are to be stitched either by machine or by hand. When stitched by machine there shall be at least 9 stitches through each pair of holes. When stitched by hand, at least 8 stitches of single thread or 4 stitches of double thread must pass through each pair of holes. In case of hand stitching the thread strand shall be wound round the stitches three times when double or six times when single to form a shank.

10. Bottom. The bottom of the shorts shall be hemmed 6 cm after raw edges turned in. The circumference of the legs shall be 15 cm more than the corresponding part of the thighs. The shorts shall reach from 10 cm to 12 cm above the centre of the knee cap. The shorts shall be assembled with lock stitches regulated at 45 to 50 stitches per dm (10 cm). All ends shall be securely fastened off and loose threads trimmed off.

11. Size Scale. The shorts shall conform to the dimensions specified in the size scale given in Appendix J to these specifications.

12. Sealed Sample. As per Para 2 of Appendix B, Chapter 1.

13. Marking of Stores. Each pair of shorts shall be provided with a woven size label showing nomenclature, size and cat no of the store, the manufacturer's name or his recognised trade-mark and the month and year of manufacture. The label shall be of white art silk and threads of contrast colour will be used. It shall be attached to the waist band lining on the right hand side at the centre.

Inspection ▼

14. Acceptance Mark. It shall be affixed on the inside of the waist band at the back within 10 cm of the marking label. Only brass acceptance mark of 1.3 cm size shall be used.

15. Pre-inspection Declaration. As given in Para 3 of Appendix B, Chapter 1.

Warranty ▼

16. As given in Para 4 of Appendix B, Chapter 1.

Packing and Marking ▼

17. As given in Appendix C, Chapter 1.

Sketches ▼

18. Sketches showing various details/dimensions are placed at Appendix Y to this Chapter.

SIZE SCALE - WHITE SHORTS

Size cm	Side Length cm	Leg Length cm	Size Round			
			Seat cm	Waist cm	Bottom cm	Length of Zip cm
70	44	18	103	70	54	18
73	47	20	106	73	55	18
77	47	20	110	77	56	18
80	50	22	113	80	57	20
84	50	22	117	84	58	20
87	53	24	120	87	59	20
91	53	24	124	91	60	20
92	56	25	125	92	62	22
Tolerance	±.5		±.5	±.5		

Notes : (For all sizes)

1. Opening of side pockets between tacks - 16 cm.
2. Width of waist belt at front - 5 cm.
- at back - 5 cm.
3. Width of bottom hem - 6 cm.
4. Inside pocket length - 12 cm.
- depth - 9 cm.
5. Length of front extension band on waist - 8 cm.

WHITE SHORTS

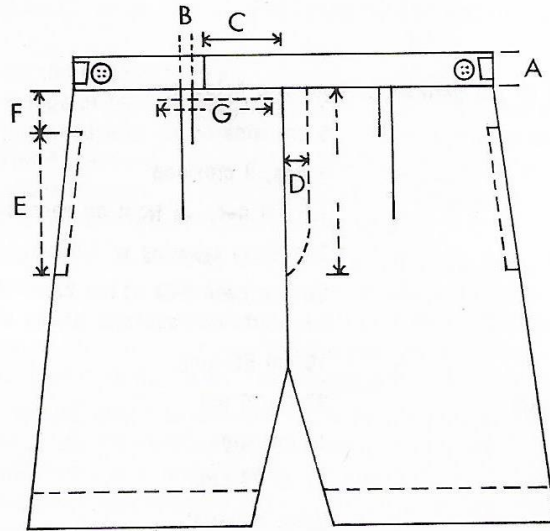

FRONT

Legend

- | | | |
|-------------------------|---|---------|
| A - Waist-band width | - | 5.0 cm |
| (front & back) | | |
| B - Pleat in front | - | 1.5 cm |
| (outward facing) | | |
| C - Extension piece | - | 8.0 cm |
| D - Fly front | - | 3.0 cm |
| (Tapering to | | |
| 1.5 cm at bottom) | | |
| E - Pocket opening | - | 16.0 cm |
| F - Distance of pocket | | |
| from waist-band | - | 4.0 cm |
| G - Inside thief pocket | - | 12x9 cm |
| H - Bottom fold | - | 6.0 cm |
| J - Hip pocket opening | - | 12.0 cm |

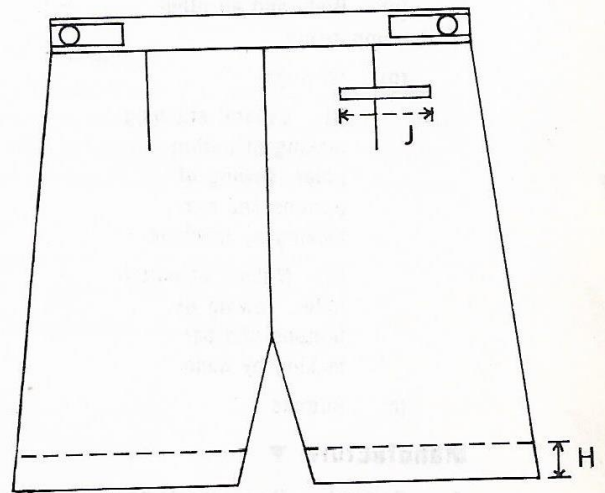

BACK

CHAPTER - 2

WHITE FULL SLEEVED SHIRT (NHQ/DCV/9511/S/02)

Applicability ▼

1. These specifications cover the requirement of white full sleeved shirt worn with black winter jacket (No 1 & 3 dresses), winter and summer mess jackets (No 5 & 6 dresses) and black jersey (No 7 dress).

Salient Features ▼

2. The salient features of the garment are as under :-
 - (a) Chest pocket – 13 cm deep X 12.5 cm wide.
 - (b) Front opening folds – 4.5 cm.
 - (c) Buttons – 6 (1.1 cm dia).
 - (d) Collar – 3.5 cm centre of the back, 7 cm fall at the front.
 - (e) Cuff – 7 cm wide.
 - (f) Pleats – Two at back.
 - (g) Yoke – 5.5 cm at centre and at ends.

Materials ▼

3. The shirt shall be manufactured from the following materials:-

Items	Material
(a) Body and all other components	– Plain weave white polyester cotton cloth (70 : 30).
(b) Lining for collar	– HDPE coated fusible interlining fabric.
(c) Sewing of shirt including overlocking, buttons and button holes	– White spun polyester sewing thread.
(d) Buttons 1.1 cm dia.	– White translucent buttons.

Manufacture ▼

4. **General.** The shirt shall be tailored from bright white polyester cotton cloth. The front portion of the shirt shall be in two pieces i.e. open front. The forepart shall be cut wide enough to obtain 4.5 cm wide turn in on the left side and 4.5 cm wide button stand (both including selvages) on the right side up to the bottom.
5. **Pocket.** There shall be one plain patch pocket on the left chest. Top of the pocket shall be made by stitching the raw edges with a turn in of 1 cm and then turning the seam inside by 2 cm so that no seam is visible at the upper part of the pocket. The bottom corners of the pocket shall be finished diagonal cut of a square. The pocket opening shall be secured by a triangular tack by machine stitching at both ends. The length of the pocket shall be 13 cm and the width 12.5 cm.
6. **Buttons.** The shirt shall be provided with six white translucent buttons (including collar button) 1.1 cm diameter on the right hand side of front opening. The button-holes shall be made at corresponding positions on the left hand side.
7. **Back.** The back shall be in one piece having two pleats 1 cm deep outward facing at waist and shall be stitched between two layers of yoke at shoulder. The front and back pieces shall be joined together at the sides by plain stitching and then overlocked with white polyester sewing thread. The front pieces shall be joined at the shoulder by first stitching with the under piece of the yoke and then with the outer piece. The bottom edges of the front and back portions shall be hemmed 6 mm with raw edges turned in. There shall be rounded vent at each side at the bottom of the shirt. The width of the yoke at the centre and at ends shall be 5.5 cm.

8. Collar. The collar shall be made from two layers of the basic material and each layer will be in a single piece. The interlining material is to be placed in between the two layers of the basic fabric. It is to be ensured that the laminated surface of the interlining material is kept facing the outer layer of the collar. The collar is then to be fused by heat process. The upper stitching of the collar shall be finished with a uniform distance of 5 mm from the border. The finished collar shall be attached to the gorge with two rows of machine stitching i.e. one row from inside and another row from outside. The width of the collar folded at centre of back shall be 3.5 cm and fall at front 7 cm.

9. Sleeves. The shirt shall have full sleeves in one piece with single cuff 7 cm wide and finished with underarm plain stitching and then overlocked with white polyester sewing thread. The cuff will have two 1 cm pleats extending towards elbow, one on each side. The sleeves shall be attached to the armhole by plain seam. The sleeve length shall be restricted so that the edge of the sleeve is up to the wrist joint.

10. Stitching of Buttons. The buttons shall be stitched with not less than 16 stitches of single thread or 8 stitches of double thread through the buttons. When the buttons are stitched by hand, the thread shall be wound round the stitches three times when double or six times when single thread is used to form a shank.

11. Button-holes. The button-holes shall be made with not less than 8 stitches per cm when made by hand or 9 stitches per cm when made by machine. The button-holes may be eyelet end type or bar end type and be either bar tacked or taper finished.

12. Stitching. The shirt shall be assembled throughout with lock stitches regulated at 40 to 45 stitches per dm (10 cm). All ends shall be securely fastened off.

13. Size Scale. The shirt shall conform to the dimensions specified in Appendix D to these specifications.

14. Sealed Sample. As given in Para 2 of Appendix B, Chapter 1.

15. Marking. Each shirt shall have a white cloth label 14 cm x 2.5 cm stitched on the yoke lining inside below the collar seam. It shall have the following details woven with contrast colour threads :-

- (a) Brief nomenclature.
- (b) Cat no. and size.
- (c) Manufacturer's name and/or his recognised trade-mark.
- (d) Month and year of manufacture.

Inspection ▼

16. Acceptance Mark. Textile marking stamp of 1.3 cm size shall be used to stamp on the reverse of the cloth label using indelible ink in token of having accepted the stores after due inspection.

17. Pre-inspection Declaration. As given in Para 3 of Appendix B, Chapter 1.

Warranty ▼

18. As given in Para 4 of Appendix B, Chapter 1.

Packing and Marking ▼

19. As given in Appendix C, Chapter 1.

Sketches ▼

20. Sketches showing various details/dimensions of the shirt are placed at Appendix Q to this Chapter.



Appendix D
(Refers to Para 13
Chapter 2)

SIZE SCALE - WHITE FULL SLEEVED SHIRT

Size cm	Size Round			Length			Sleeves			Length of collar from front of button hole to centre of button cm	Distance from depth of scye to top of vent cm	Distance of last button hole from bottom of collar cm
	Under arm when butt- oned cm	Waist when butt- oned cm	Seat at curva- ture point cm	Front from neck point to bottom excluding yoke cm	Back from bottom edge of collar to bottom of shirt cm	Yoke cm	Length from shoulder point cm	Vent from tack to bottom of cuff cm	Cuff from button hole to centre of button cm			
1	2	3	4	5	6	7	8	9	10	11	12	13
34	93	82	88	70	76	41	55	18	21	34	31	43
35	96	85	91	73	79	42	58	19	21	35	33	45
36	100	89	95	73	79	43	58	19	22	36	33	45
37	103	92	98	76	82	44	61	20	22	37	35	47
38	107	96	102	76	82	45	61	20	22	38.5	35	47
39	110	99	105	79	85	46	64	21	23	39.5	37	49
40	114	103	109	79	85	47	64	21	23	40.5	37	49
42	118	107	112	82	88	48	67	23	23	42	39	51
Tolerance	±2.0	±2.0	±2.0	±1.0	±1.0	±1.0	±1.0	±0.5	±0.5	±0.5	±1.0	±0.5

Notes: (For all sizes)

1. Width of yoke at centre & ends - 5.5 cm
2. Width of collar folded at centre of back - 3.5 cm
3. width of collar fall at front - 7.0 cm
4. Pocket Length - 13.0 cm
5. Pocket width - 12.5 cm
6. Width of cuff - 7.0 cm

WHITE FULL SLEEVED SHIRT

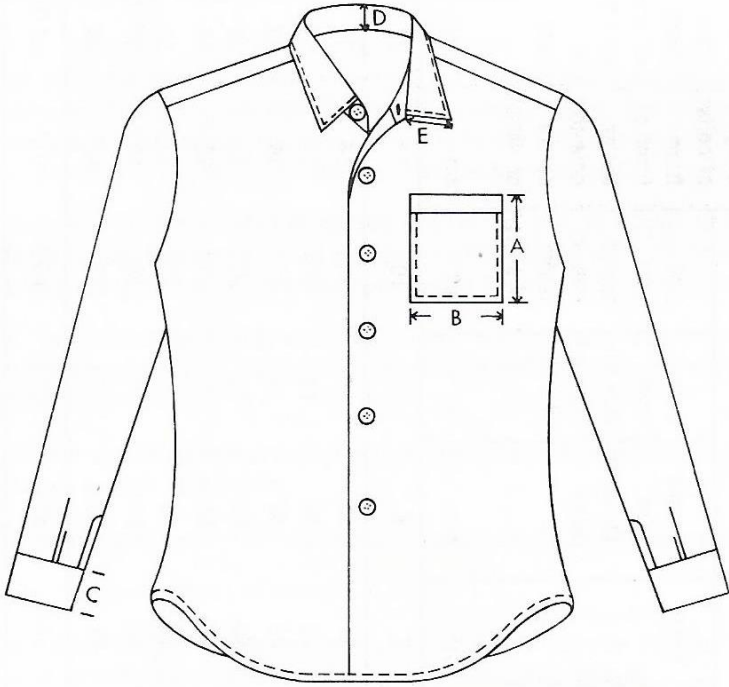

FRONT

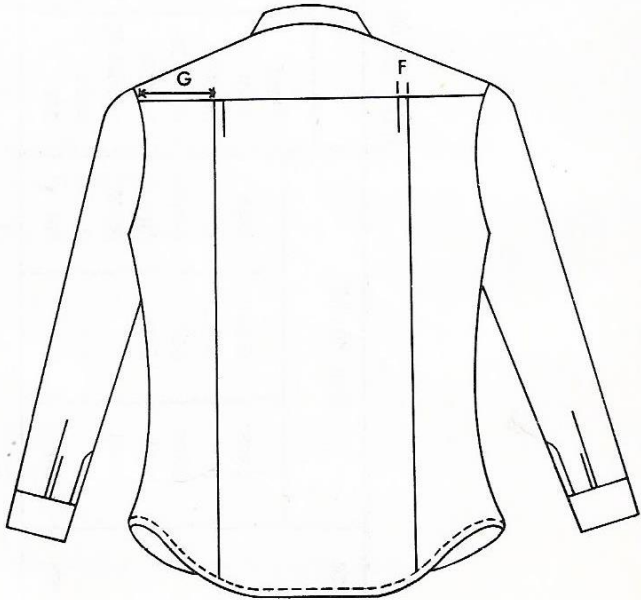

BACK

Legend

- A - Pocket length - 13.0 cm
- B - Pocket width - 12.5 cm
- C - Cuff width - 7.0 cm
- D - Collar at centre back - 3.5 cm
- E - Collar fall in front - 7.0 cm
- F - Pleat at back - 1.0 cm
- G - Distance of pleat from shoulder joint - 7.0 cm